



Finishes You've Never Seen Before®

WESTERN STATES METAL ROOFING

(877) 787-5467 • WESTERNSTATESMETALROOFING.COM

MS1.5® PANEL 1 1/2" MECHANICAL SEAM

INSTALLATION GUIDE WITH TRIM, FLASHINGS AND DETAILS

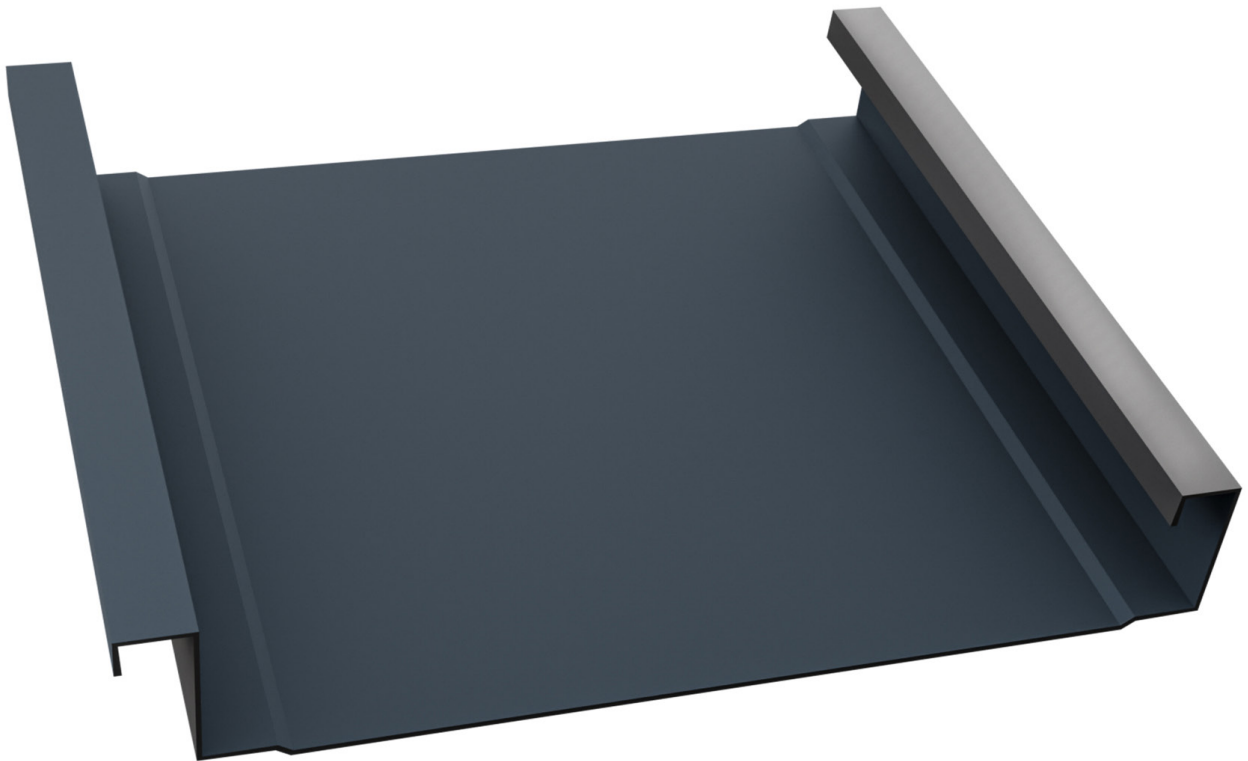

Phoenix: ☎ (602) 495-0048 ✉ sales@westernstatesmetalroofing.com | Washington: ☎ (509) 418-2833 ✉ washington-wsmr@westernstatesmetalroofing.com

Tucson: ☎ (520) 574-4247 ✉ tucsonsales@westernstatesmetalroofing.com | Texas: ☎ (972) 843-4343 ✉ texas-sales@westernstatesmetalroofing.com

Western States "MS-1.5® Standing Seam"

Installation, Flashings & Shop Drawing Detail Guide

Table of Contents

Section	Page	Section	Page
Special Design Considerations.....	1	Rib Cover 3D.....	29
Notes to Designer /Installers.....	2	Rake Wall Detail (90 Degree Seam).....	30
Fastener Placement and Selection.....	3-4	Rake Wall Detail (180 Degree Seam).....	31
Panel Profile.....	5	High Eave Detail (Fixed).....	32
Stiffening Ribs.....	6	High Eave Detail (Floating)	33
Eave Hem.....	7	Ridge Detail (Floating).....	34
Key Roof Plan.....	8	Ridge Detail (Fixed)	35
Standard Trims	9-12	Valley Detail (Fixed).....	36
Clip Spacing.....	13	Valley Detail (Floating).....	37
Fixed Lap Detail.....	14	Bull Nose Eave Detail.....	38
Floating Lap Detail.....	15	Half Valley Detail (Fixed).....	39
Swage Detail.....	16	Half Valley Detail (Floating).....	40
Fixed Eave Detail.....	17	Head Wall Detail (Floating).....	41
Floating Eave Detail.....	18	Notes.....	42
Gutter Detail.....	19	Custom Trim.....	43
Gutter Splice Detail.....	20		
Rake Detail (180 Degree Seam).....	21		
Rake Detail (90 Degree Seam).....	22		
Head Wall Detail (Fixed).....	23		
L/H Pitchbreak Detail (Fixed).....	24		
L/H Pitchbreak Detail (Floating).....	25		
H/L Pitchbreak Detail (Fixed).....	26		
H/L Pitchbreak Detail (Floating).....	27		
Rib Cover Detail.....	28		

Western States "MS-1.5"® Standing Seam™

Installation, Flashings & Shop Drawing Detail Guide

Special Design Considerations

The details contained in this guide are proven industry details and are intended to be used as a design aid and installation guide. It does not depict all situations that may be encountered on all projects. Modifications are the responsibility of the designer/owner/installer.

Consideration should be given for fit for purpose, building use, climate conditions such as temperature, snow, wind, and moisture, governing building codes, and maintenance.

It is highly recommended that all trims and flashings be of the same material as the panels (metal, gauge, finish) to ensure long term performance and durability. Where possible, flashing edges should be hemmed to strengthen the edge and protect the cut edge from exposure.

Acceptance

Use of this manual is strictly voluntary. Details that are provided are to be used as a guide only. Details may not be applicable for all situations. This guide provides one standard detail and WSMR accepts that other installation details may be needed and other details may exist. WSMR makes no guarantee as to the weather tightness of the system or details found within this guide. The information in this manual is believed to be correct and accurate at the time of printing. WSMR reserves the right to change details, discontinue products, change designs at any time without incurring obligation. It is best to consult your design engineer for recommendations.

Underlayment

There are many types of underlayments on the market today that are all designed with a special purpose depending on the type of metal and profile. Many different types of metal will require a different type of underlayment. It is best to consult your design engineer for recommendations.

WSMR Recommends SharkSkin Ultra SA

Not all conditions require an underlayment, however, metal siding is susceptible to condensation and it is recommended that an appropriate underlayment be used on all wood substrates to protect the structure during installation. For added protection from rain and

snow, it is recommended to use rubberized ice and water shield.

Snow Design

Design and dimensions must be the proper width to accommodate high snow, rain, ice, and slope conditions. If possible, splices, penetrations, should be minimized in areas of high snow and ice accumulations. Details found in this manual may not pertain in areas of high snow and ice accumulations.

Panel coverage and fastening

Normal panel width of MS-1.5"® Standing Seam panels are 12", 14", 16" and 18" wide coverage. However depending on the finish selected and the required coil feed, other sizes may be available. Please consult with your WSMR representative for details and fastening recommendations.

Safety and Maintenance

Extreme care should always be used when working with metals. Safety should always be a top priority and approved fall protection and equipment as approved by OSHA should always be used. No structure is immune to severe weather, or is completely maintenance free. To keep your siding performing as it was designed, an inspection and comprehensive maintenance program should be implemented.

References

For other installation techniques and details, The Sheet Metal and Air Conditioning Contractors National Association Inc. (SMACNA) and NRCA manuals are great resources for working with sheet metal.

Technical Assistance

Contact your WSMR sales or technical representative for any additional information or assistance. To insure you have the latest information available, please inquire or visit our web sites at www.westernstatesmetalroofing.com

Western States "MS-1.5"® Standing Seam™

Installation, Flashings & Shop Drawing Detail Guide

Notes to Designer and Installers

The details contained in this guide are proven industry details and are intended to be used as a design aid and installation guide. It does not depict all situations that may be encountered on all projects. Modifications are the responsibility of the designer/ owner/ installer. Consideration should be given for fit for purpose, building use, climate conditions such as temperature, snow, wind, and moisture, governing building codes, and maintenance. It is highly recommended that all trims and flashings be of the same material as the panels (metal, gauge, finish) to ensure long term performance and durability. Where possible, flashing edges should be hemmed to strengthen the edge and protect the cut edge from exposure.

Framing and Substrates

"MS-1.5"® Standing Seam™ panels are used over all type of substrates like steel framing, open purlins, spaced sheathing, and wood surface such as plywood. Most details in this guide are shown with panels attached to open framing.

Oil Canning

Oil canning is a condition common with flat metal surfaces. This waviness is caused by steel mill tolerances, forming, variations in the structures surfaces, and hardness of the steel. Measures are taken at the roll forming process, like profile design, steel gauge, corrective leveling, to minimize the effects of oil canning. Oil canning is a characteristic of steel and can not be eliminated totally and therefore is not reason for rejection of the panels.

Job Site Storage

While waiting to be installed on the job site, storage of panels, trim crates, and flat sheet should be sloped in order to allow for proper moisture run off. One end should be elevated so as not to allow ponding of water on the metal surface. When using tarps for protection, proper ventilation should be provided to prevent condensation. Moisture or

condensation that is trapped inside a bundle can lead to white rust on sheeting. WSMR assumes no responsibility of liability for damage to our products which occurs in the possession of the consignee or which we deem to be improper handling and storage. Protective plastic film on trim or panel should be removed within 90 days. Failure to follow these instructions may void the warranty.

Slope Requirements

The panels in this install guide should be used on slopes 1:12 or greater with mastic.

Condensation, Insulation, & Ventilation

It is the designer's responsibility to determine the need and composition of condensation control materials including insulation and vapor retarders, as well as ventilation requirements. Metal roofing is susceptible to condensation, and its control should be carefully considered.

Pinning Requirements

The MS1.5® panel must be "pinned" at one end only to resist the "drag" load caused by weight of the panels, live load, and snow loads. The intensity of the drag load is a function of the slope, the loads involved, and the panels. Please consult a design engineer for exact pinning requirements.

Expansion & Contraction

Both the panels and flashing must allow for expansion and contraction of the materials, especially where long lengths are used.

The overlap between the hidden cleat and the turned-under end of the panel at the eave may need to be increased to accommodate thermal movement when 30ft + sheets are used.

Valleys

Valley dimensions must be the proper width to account for roof slope, snow, ice and rain conditions. Details found in this guide may not pertain to areas of high snow and ice accumulations.

Western States "MS-1.5" Standing Seam Panel

Installation, Flashings & Shop Drawing Detail Guide

Notes to Installers:

Fastener Selection will vary depending on type and thickness of substrate. Design Calculations for clip spacing should be completed by the design engineer.

The use of Butyl tape mastic, Butyl sealants and Curing Sealants is always recommended to insure weather tight installation.

Panels and flashings should never be installed in contact with dissimilar metals. Use only those flashings and accessories designed for use with this panel.

Panel clip attachment screws must be long enough to fully penetrate through roof deck substrate or penetrate solid lumber at least one inch.

Exposed Trim Fasteners should have sealing washers and be coated to provide protection against corrosion.

Screws must be properly driven to ensure holding strength and proper seal. (see diagram)
Recommended drill speed is 2000rpm. Improper setting of drill speed can lead to snapping of screw heads.

Pre drilling of screw holes may be necessary with heavy gauge metals

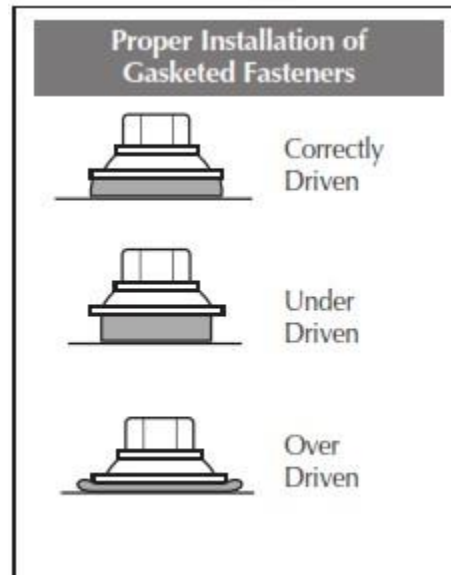

Western States "MS-1.5® Standing Seam"

Installation, Flashings & Shop Drawing Detail Guide

Fastener Selection

Description

Application

14 x 7/8" Lap Self tap

Used to attach trims.



#10-12 x1" Pancake head Wood
#10-12 x 1" SD PH Self Driller Steel

Used to attach Panel clips.
Used to secure trims to substrates.

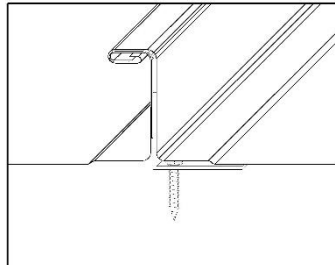
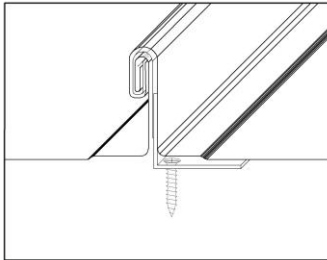

*Double Seam UL Rated

1/8" Stainless Rivets

Used for Trim to Trim attachment or trim to wall panels.



#9 x 1" Woodgrip
#9 x 1.5" Woodgrip
#9 x 2" Woodgrip

Used for panel attachment



#12-14 x 1" Self Driller
#12-14 x 2" Self Driller

Used for Metal to Metal
Used for Metal to Metal

22/18 ga. Floating Clip

Floating clip allows for thermal movement.

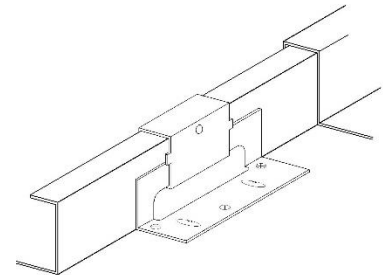

22 ga. Fixed Clip

Fixed Clip

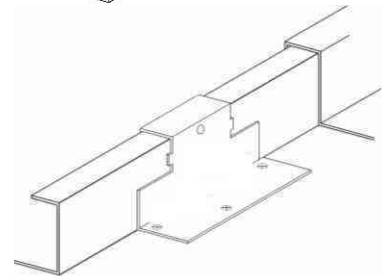

WSMR will not be responsible for final screw/clip selection. This guide is just a reference tool to be used. Please consult a design engineer for load and design calculations.

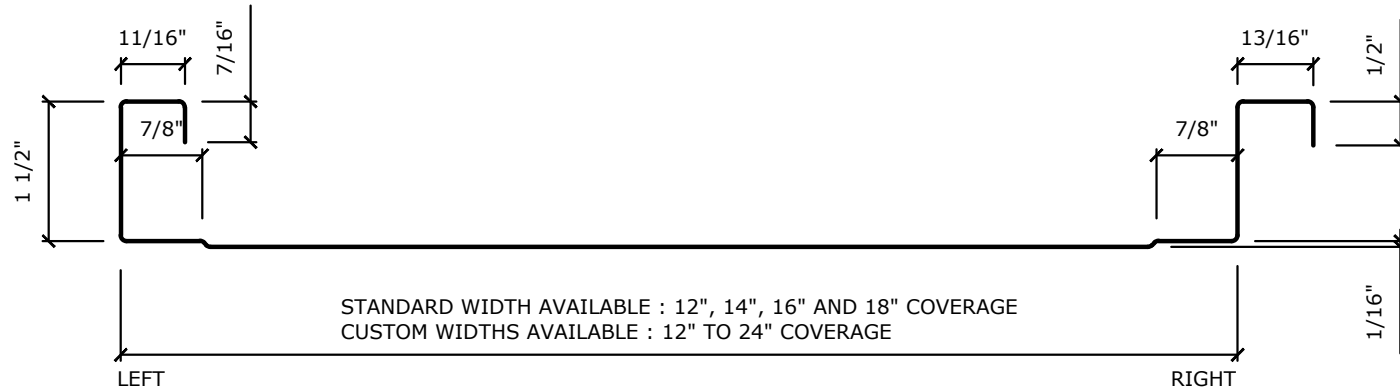
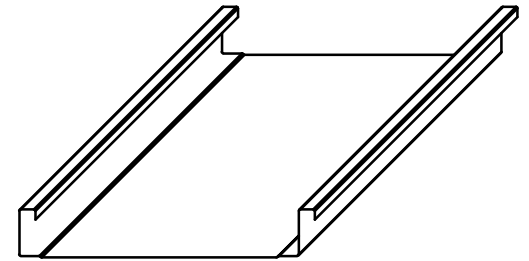

Western States Metal Roofing	SCALE:	TITLE / PART NAME:		
	DRAWN:	MS1.5 [®] STANDING SEAM		
	DATE:	PRODUCT / PRODUCT LINE		
901 W. Watkins St. Phoenix, AZ 85007	CHECKED:	PART I.D.	REVISION	SHEET
	DATE:			

Copyright: The design and print is the property of Western States Metal Roofing, and must not be used, reproduced, or copied, wholly or in part without the written permission from the company. Supply of this design and print represents a confidential communication between the company and recipient.

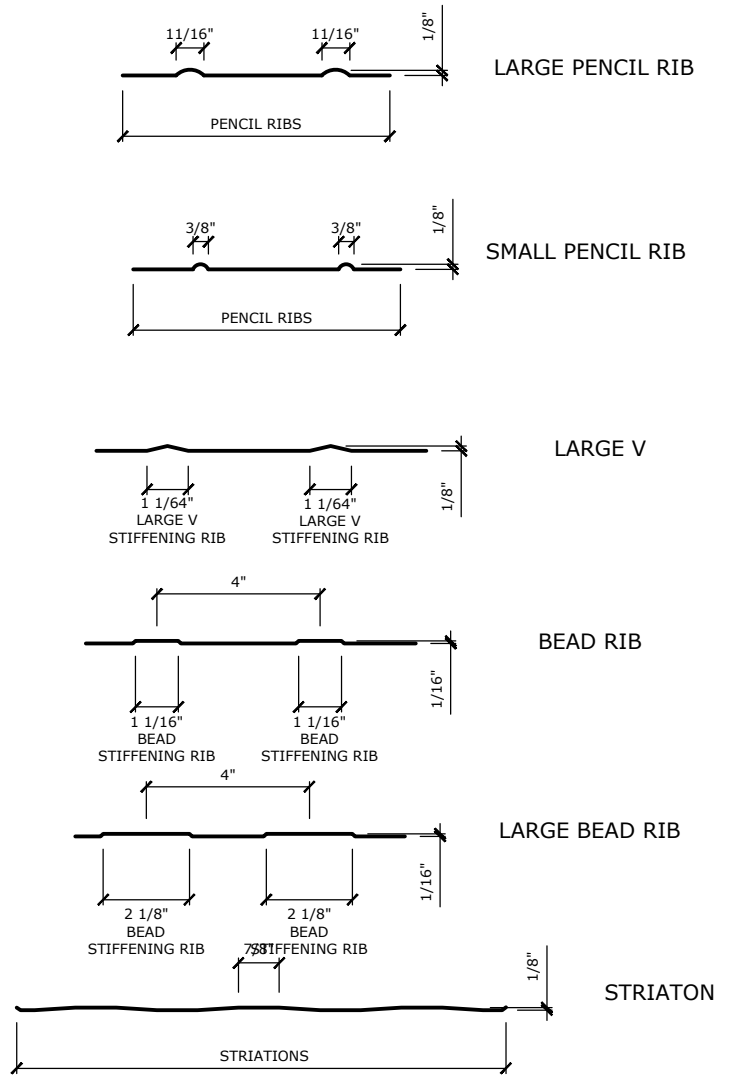
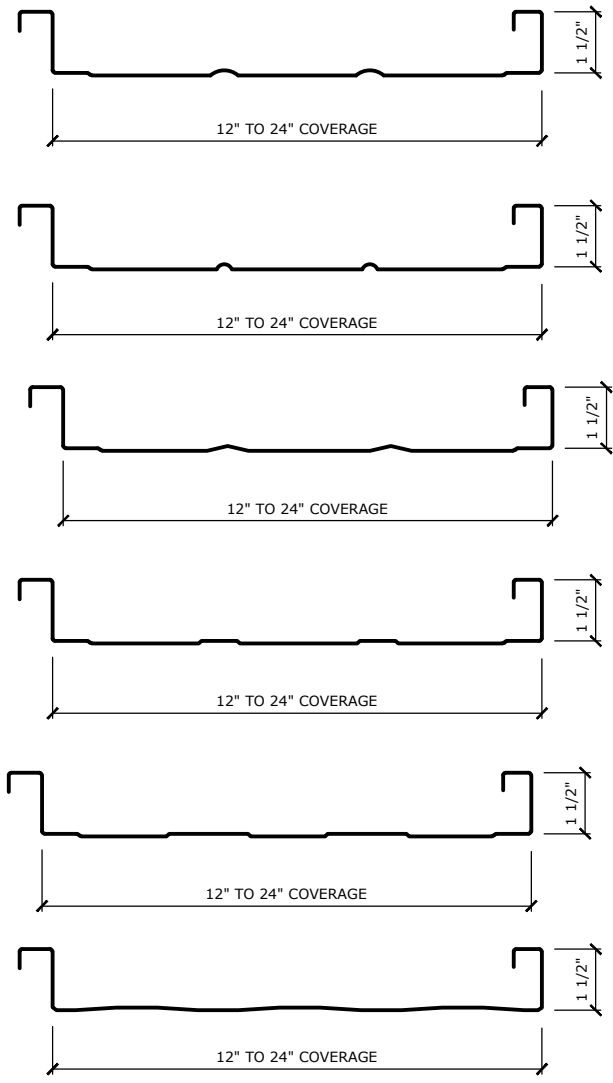

Western States Metal Roofing	SCALE:	TITLE / PART NAME: STIFFENING RIBS		
	DRAWN:			
901 W. Watkins St. Phoenix, AZ 85007	DATE:	PRODUCT / PRODUCT LINE MS1.5[®] STANDING SEAM		
	CHECKED:	PART I.D.	REVISION	SHEET
	DATE:			

Copyright: The design and print is the property of Western States Metal Roofing, and must not be used, reproduced, or copied, wholly or in part without the written permission from the company. Supply of this design and print represents a confidential communication between the company and recipient.

MS 1.5® STANDING SEAM

Installation, Flashings & Shop Drawing Detail Guide

EAVE HEM

STEP ONE

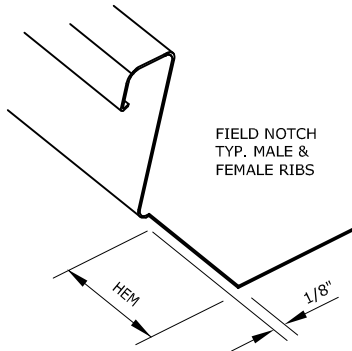

STEP TWO

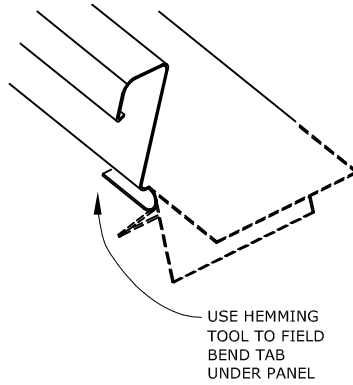

STEP THREE



HEMMED & SEAMED
MS2® PANEL

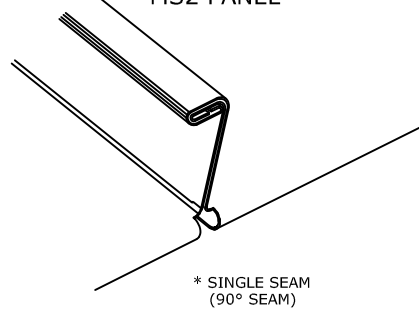

HEMMED & SEAMED

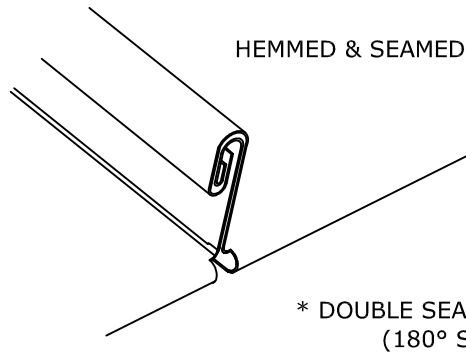

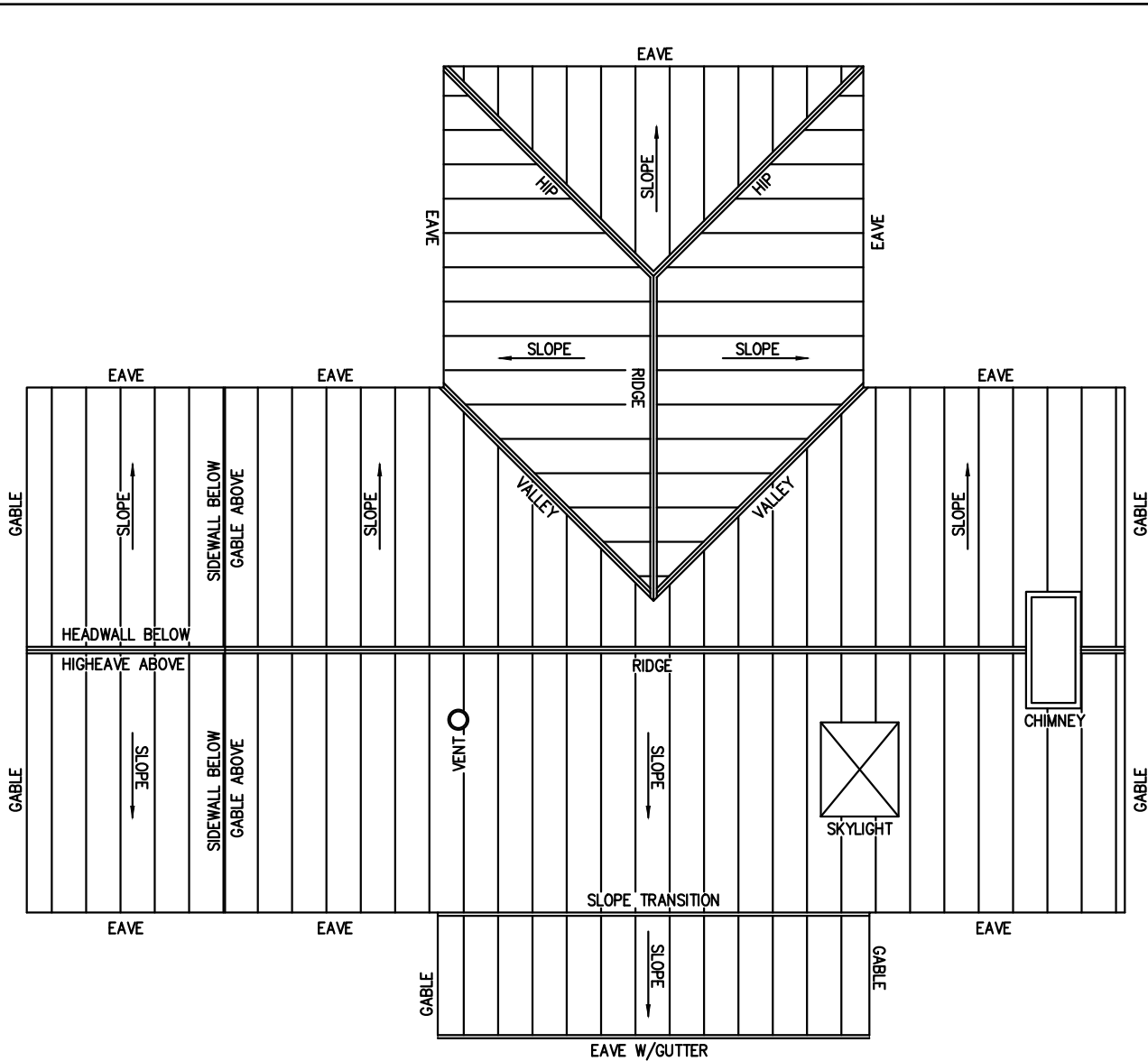

FLASHING TYPE	DETAIL NO.
STANDARD TRIM	WSD-ST1
STANDARD TRIM	WSD-ST2
STANDARD TRIM	WSD-ST3
STANDARD TRIM	WSD-ST4
FIXED LAP DETAIL	WSD-S1
FLOATING LAP DETAIL	WSD-SW2
FIXED EAVE DETAIL	WSD-S3
FLOATING EAVE DETAIL	WSD-SW4
EAVE WITH GUTTER DETAIL	WSD-SW5
EAVE GUTTER SPLICE DETAIL	WSD-CS6
RAKE DETAIL (180° SEAM)	WSD-SW7
RAKE DETAIL (90° SEAM)	WSD-SW8
FIXED HEADWALL DETAIL	WSD-SW9
HIGH TO LOW TRANSITION FIXED DETAIL	WSD-W10
HIGH TO LOW TRANSITION FLOATING DETAIL	WSD-W11
LOW TO HIGH TRANSITION FIXED DETAIL	WSD-W12
LOW TO HIGH TRANSITION FLOATING DETAIL	WSD-W13
TURN DOWN KNEE DETAIL	WSD-W14
RAKE WALL DETAIL (90° SEAM)	WSD-W15
RAKE WALL DETAIL (180° SEAM)	WSD-W16
FIXED HIGH EAVE DETAIL	WSD-W17
FLOATING HIGH EAVE DETAIL	WSD-W18
FLOATING RIDGE & HIP DETAIL	WSD-W19
FIXED RIDGE & HIP DETAIL	WSD-W20
FIXED VALLEY DETAIL	WSD-W21
FLOATING VALLEY DETAIL	WSD-W22
BULL NOSE EAVE DETAIL	WSD-W23
HALF VALLEY DETAIL FIXED	WSD-W24
HALF VALLEY DETAIL FLOATING	WSD-W25
HEAD WALL DETAIL FLOATING	WSD-W26
MISC. NOTES	WSD-MN27
CUSTOM TRIM SHEET	WSD-CT28



Western States Metal Roofing

901 W. Watkins St.
Phoenix, AZ 85007
www.westernstatesmetalroofing.com

Phone: (602) 495-0048
Fax: (602) 261-7726
877-PURLINS (787-5467)

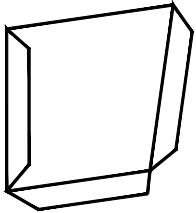
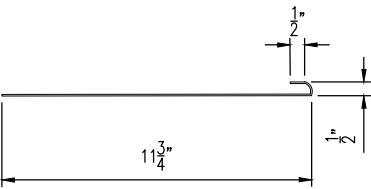
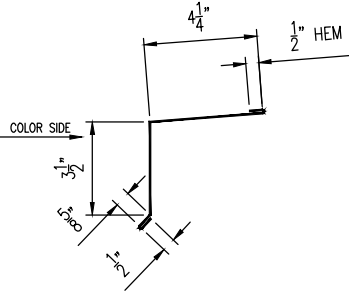
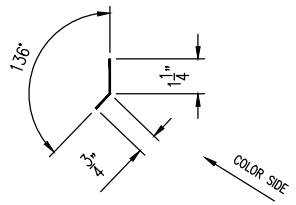
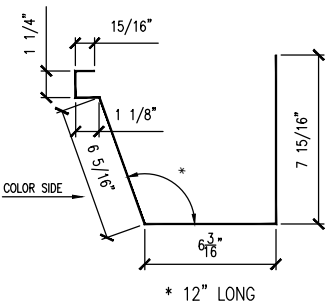
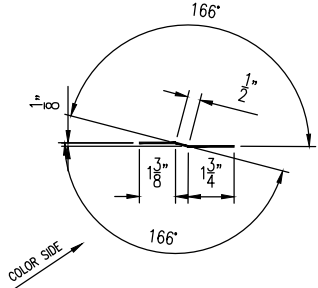
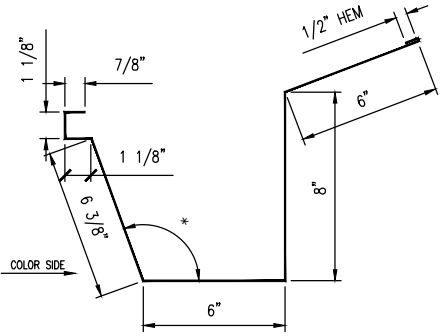
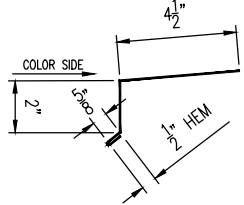
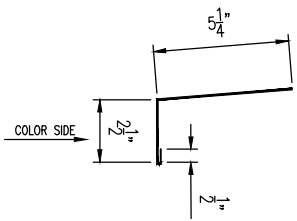
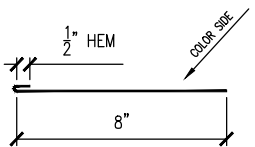
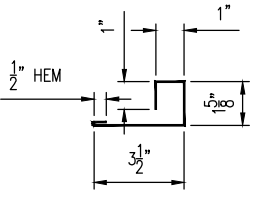
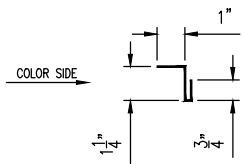

DETAIL:		
KEY ROOF PLAN		DATE:
	A	11-12-25
PANEL TYPE: MS1.5® STANDING SEAM		REV:
		DETAIL #:

<p>GUTTER END CAP WS-1300</p> 	<p>16 GA. BACKUP PLATE WS-1301</p> 	<p>EAVE FLASHING WS-1302</p> 	<p>PANEL CLEAT WS-1303</p> 
<p>GUTTER SPLICE WS-1304</p> <p>* To Be installed on outside of Gutter</p> 	<p>JOGGLE CLEAT WS-1305</p> 	<p>GUTTER WS-1306</p> 	<p>OPTIONAL EAVE TRIM WS-1307</p> 
<p>OPTIONAL EAVE FLASH WS-1308</p> 	<p>GUTTER STRAP WS-1309</p> 	<p>18 GA. PANEL RECEIVER WS-1310</p> 	<p>ANGLE TRIM WS-1311</p> 



Western States Metal Roofing

901 W. Watkins St.
Phoenix, AZ 85007
www.westernstatesmetalroofing.com

Phone: (602) 495-0048
Fax: (602) 261-7726
877-PURLINS (787-5467)



STANDARD TRIMS

PANEL TYPE:
MS1.5® STANDING SEAM

	DATE:
A	11-12-25
REV:	
DETAIL #:	MS1.5-WSD-ST1

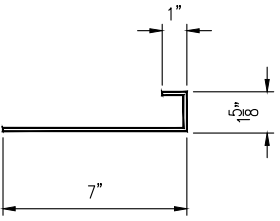
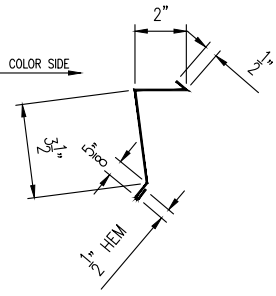
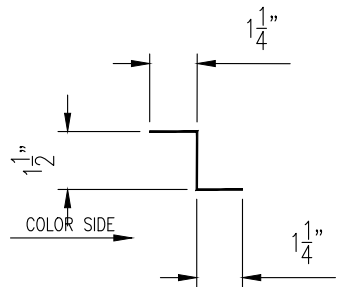
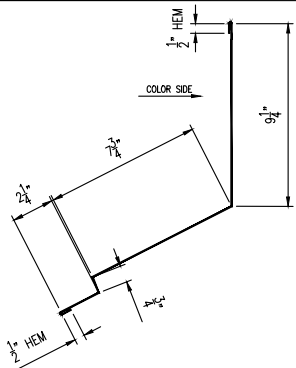
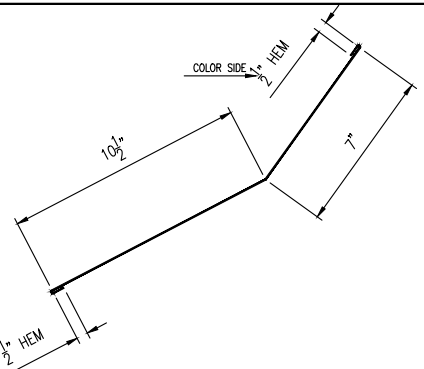
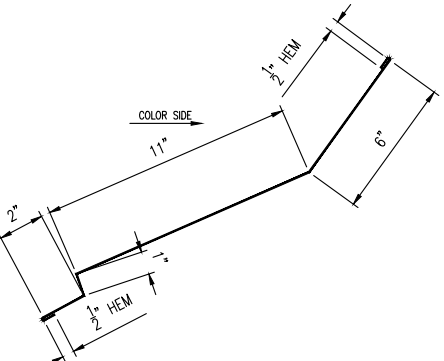
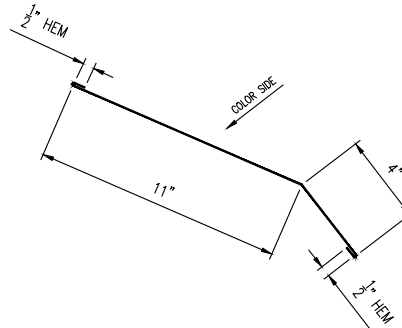
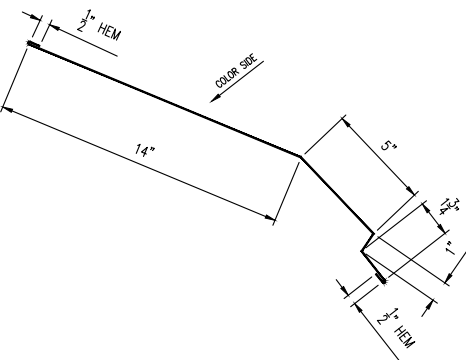
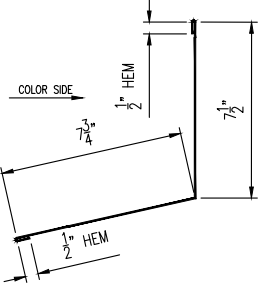
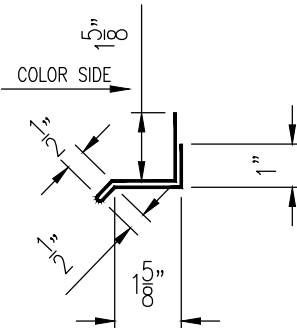
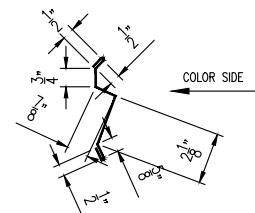
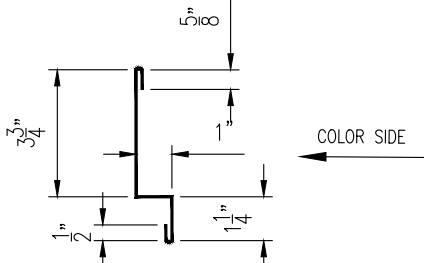
<p>18 GA CONT PANEL END SUPPORT WS-1312</p> 	<p>REGLET FLASHING WS-1313</p> 	<p>ZEE CLOSURE WS-1314</p> 	<p>HEAD WALL FLASHING WS-1315</p> 
<p>TRANSITION TRIM WS-1316</p> 	<p>TRANSITION TRIM WS-1317</p> 	<p>TRANSITION TRIM WS-1318</p> 	<p>TRANSITION TRIM WS-1319</p> 
<p>HEAD WALL FLASHING WS-1320</p> 	<p>SILL TRIM WS-1321</p> 	<p>REGLET FLASHING WS-1322</p> 	<p>RAKE WALL TRIM WS-1323</p> 



Western States Metal Roofing

901 W. Watkins St.
Phoenix, AZ 85007
www.westernstatesmetalroofing.com

Phone: (602) 495-0048
Fax: (602) 261-7726
877-PURLINS (787-5467)



STANDARD TRIM

PANEL TYPE:
MS1.5® STANDING SEAM

	DATE:
A	11-12-25
	REV:
	DETAIL #:
	MS1.5-WSD-ST2

<p>HEAD WALL FLASHING WS-1324</p>	<p>HIGH EAVE FLASH WS-1325</p>	<p>HIGH EAVE FLASH WS-1326</p>	<p>RIDGE/HIP TRIM WS-1327</p>
<p>RIDGE/HIP TRIM WS-1328</p>	<p>VALLEY TRIM WS-1329</p>	<p>BULL NOSE DRIP WS-1330</p> <p>*6:12 MAX PITCH</p>	<p>REGLET TRIM WS-1331</p>
<p>VALLEY TRIM WS-1332</p>	<p>DOWNSPOUT STRAP WS-1333</p>	<p>STRAIGHT DOWNSPOUT WS-1334</p>	<p>DOWNSPOUT W/KICKOUT WS-1335</p> <p>*45 DEG. BEND UNLESS NOTED*</p>



Western States Metal Roofing

901 W. Watkins St.
Phoenix, AZ 85007
www.westernstatesmetalroofing.com

Phone: (602) 495-0048
Fax: (602) 261-7726
877-PURLINS (787-5467)



STANDARD TRIM

PANEL TYPE:
MS1.5® STANDING SEAM

	DATE:
A	11-12-25
REV:	
DETAIL #:	MS1.5-WSD-ST3

DOWNSPOUT ELBOW WS-1336	DOWNSPOUT OUTLET WS-1337	GABLE TRIM WS-1338	VALLEY TRIM WS-1339



Western States Metal Roofing

901 W. Watkins St.
 Phoenix, AZ 85007
www.westernstatesmetalroofing.com

Phone: (602) 495-0048
 Fax: (602) 261-7726
 877-PURLINS (787-5467)



STANDARD TRIM

PANEL TYPE:
 MS1.5[®] STANDING SEAM

	DATE:
A	11-12-25
REV:	
DETAIL #:	MS1.5-WSD-ST4

Western States "MS-1.5® Standing Seam" Installation, Flashings & Shop Drawing Detail Guide

For maximum holding power, it is recommended that the minimum wood penetration be 1 inch. Using pancake head screw fasteners that are designed to be used with fastening clips to the metal roofing panels.

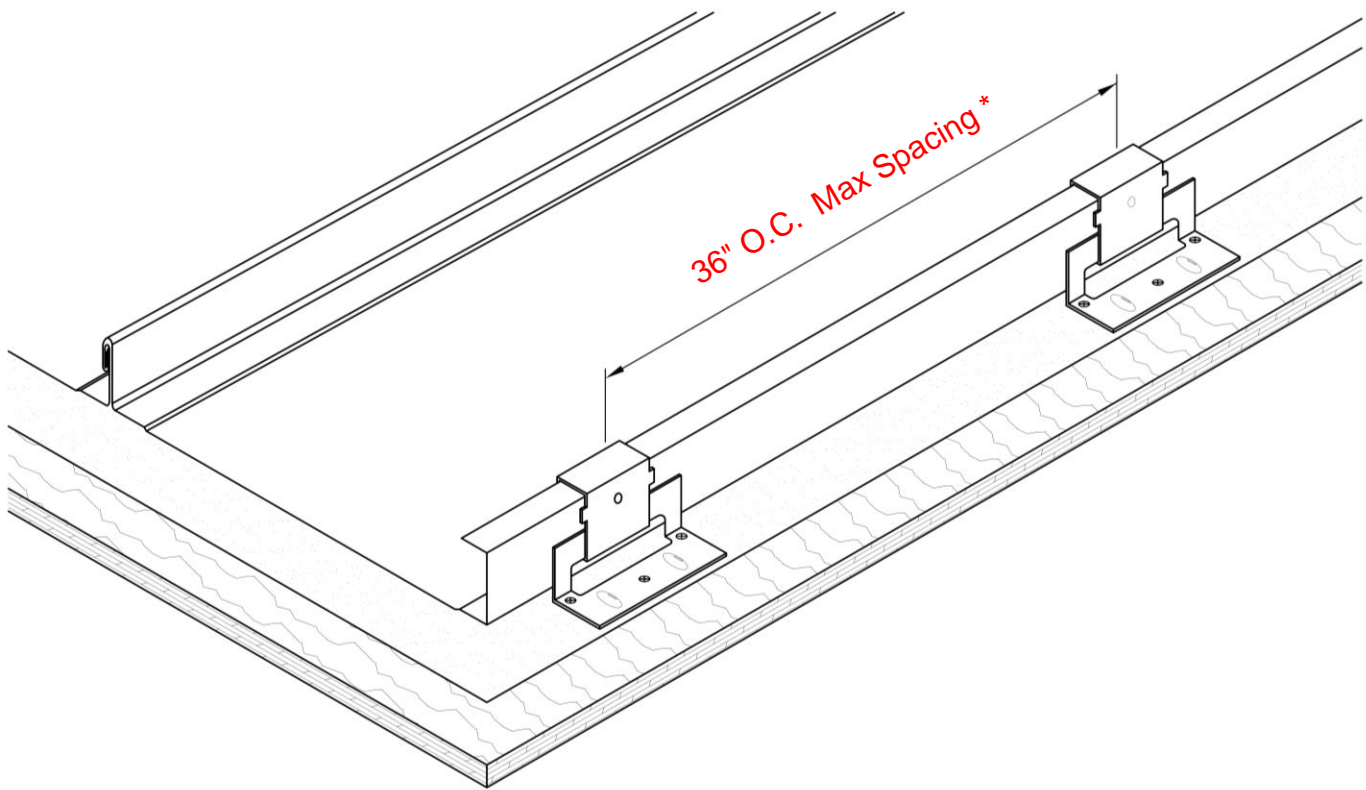

WSMR will not be responsible for final screw/clip selection. This guide is just a reference tool to be used. Please consult a design engineer for load and design calculations, which includes clips spacings.

**** WSMR Recommends Sharkskin®
Ultra SA for Underlayment.**

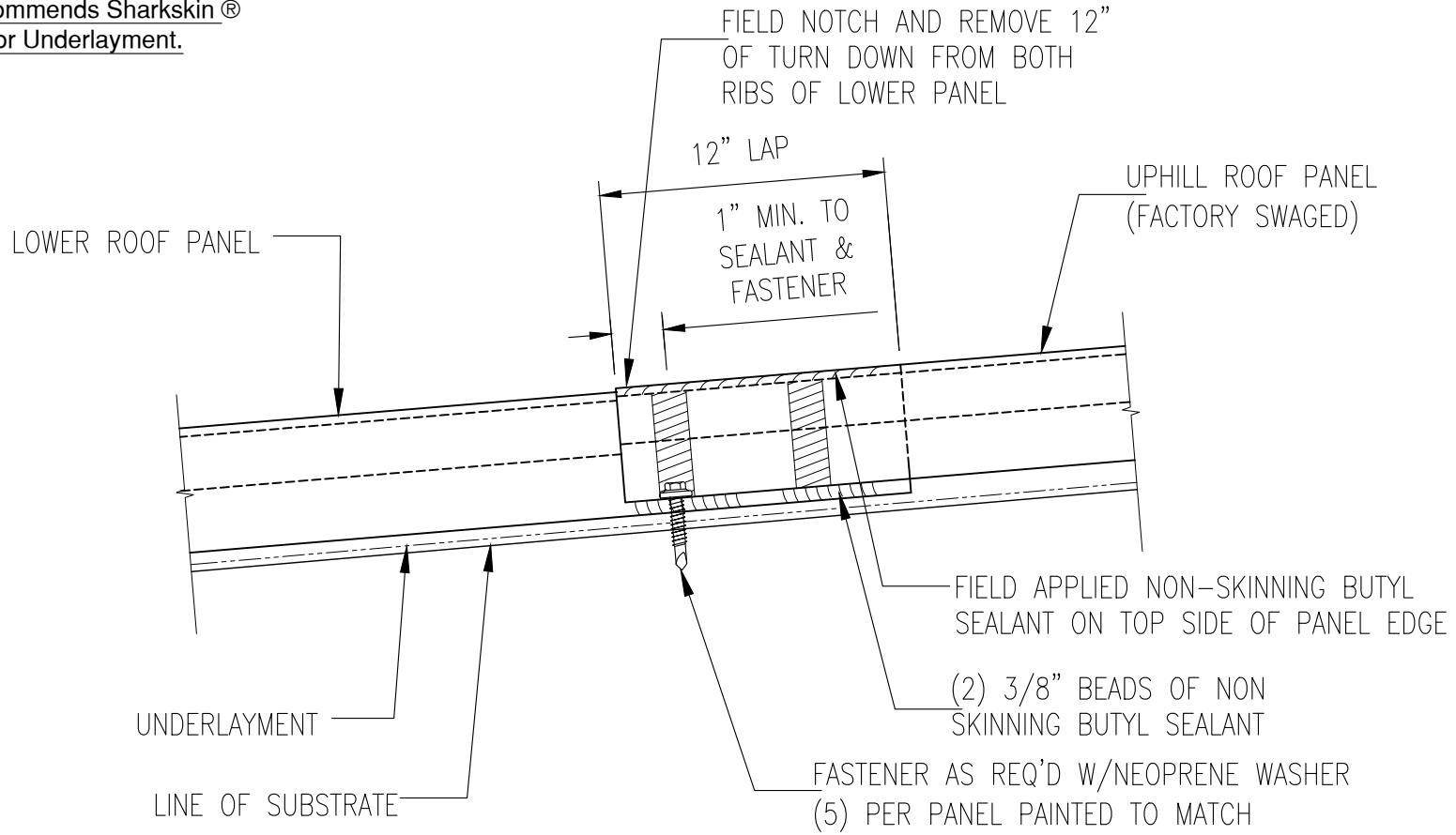

INSTALLATION NOTES:

- SWAGE TOP PANEL ONLY
- PANEL MUST BE INSTALLED LEFT TO RIGHT ONLY
- END LAPS OF ADJACENT PANELS MUST BE STAGGERED AT LEAST ONE PURLIN OR A MINIMUM OF 24" TO PREVENT MATERIAL BUILD-UP AT LAPS

GAUGE: _____	COLOR: _____
LENGTH: _____	FINISH: _____
MATERIAL: _____	

FIXED LAP DETAIL	DATE:	
	A	11-12-25
PANEL TYPE: MS1.5® STANDING SEAM	REV:	
	DETAIL #:	MS1.5-WSD-S1



Western States Metal Roofing

901 W. Watkins St.
Phoenix, AZ 85007
www.westernstatesmetalroofing.com

Phone: (602) 495-0048
Fax: (602) 261-7726
877-PURLINS (787-5467)



**** WSMR Recommends Sharkskin®
Ultra SA for Underlayment.**

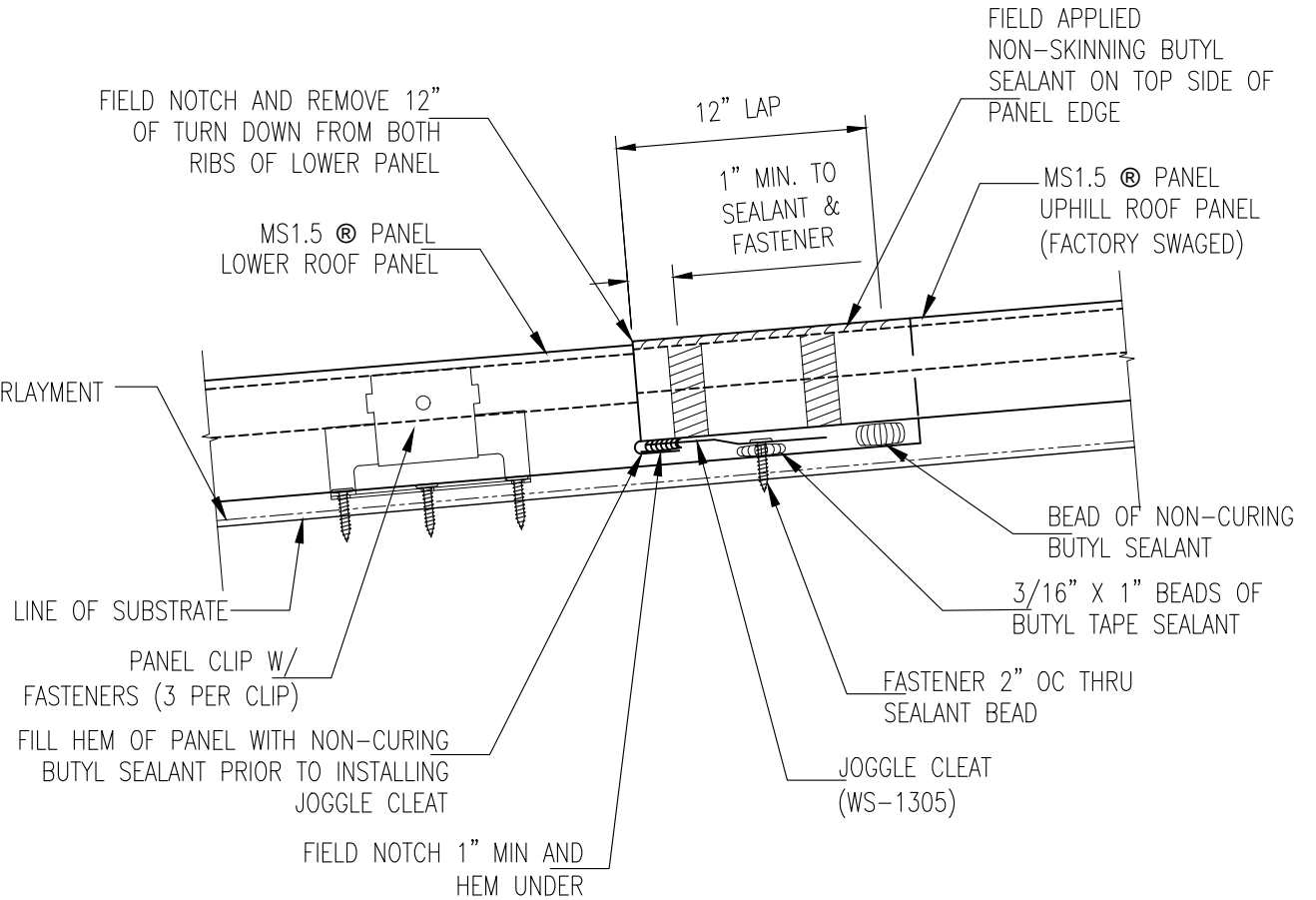
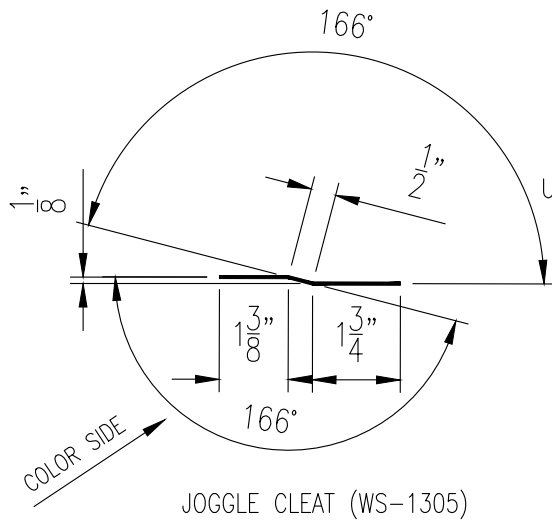

INSTALLATION NOTES:

- SWAGE TOP PANEL ONLY
- PANEL MUST BE INSTALLED LEFT TO RIGHT ONLY
- END LAPS OF ADJACENT PANELS MUST BE STAGGERED AT LEAST ONE PURLIN OR A MINIMUM OF 24" TO PREVENT MATERIAL BUILD-UP AT LAPS

GAUGE: _____	COLOR: _____
LENGTH: _____	FINISH: _____
MATERIAL: _____	



Western States Metal Roofing

901 W. Watkins St.
Phoenix, AZ 85007
www.westernstatesmetalroofing.com

Phone: (602) 495-0048
Fax: (602) 261-7726
877-PURLINS (787-5467)



FLOATING LAP DETAIL	DATE:	
	A	11-12-25
PANEL TYPE: MS1.5® STANDING SEAM	REV:	
	DETAIL #:	MS1.5-WSD-SW2

Western States "MS-1.5 Standing Seam"

Installation, Flashings & Shop Drawing Detail Guide

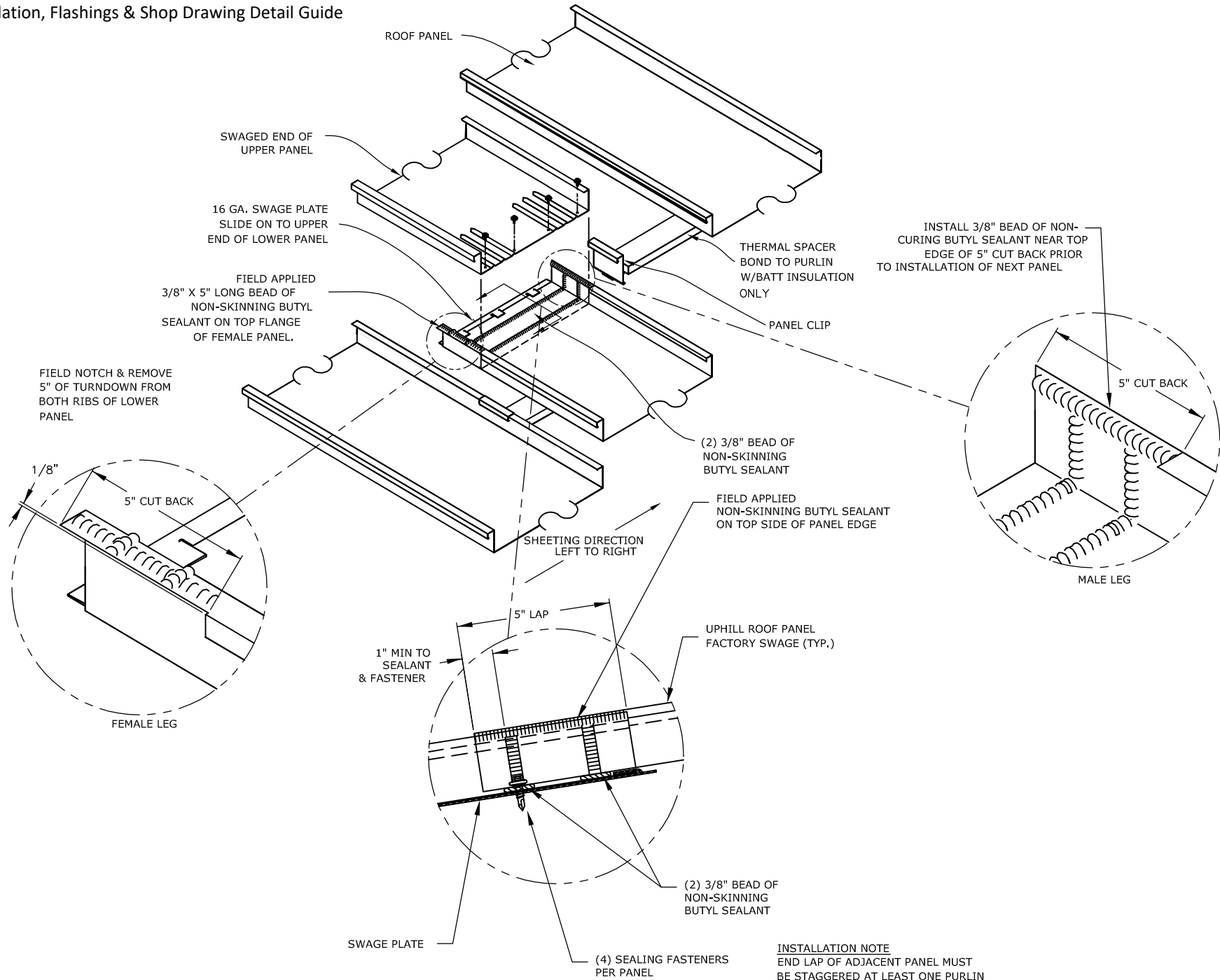

INSTALLATION NOTE
 END LAP OF ADJACENT PANEL MUST BE STAGGERED AT LEAST ONE PURLIN SPACING OR A MIN. 24" TO PREVENT MATERIAL BUILDUP AT LAPS

**** WSMR Recommends Sharkskin®
Ultra SA for Underlayment.**

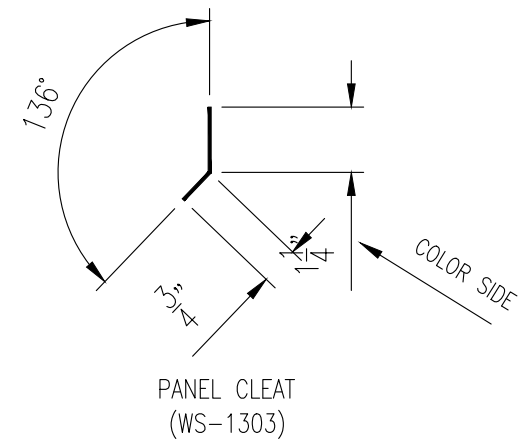
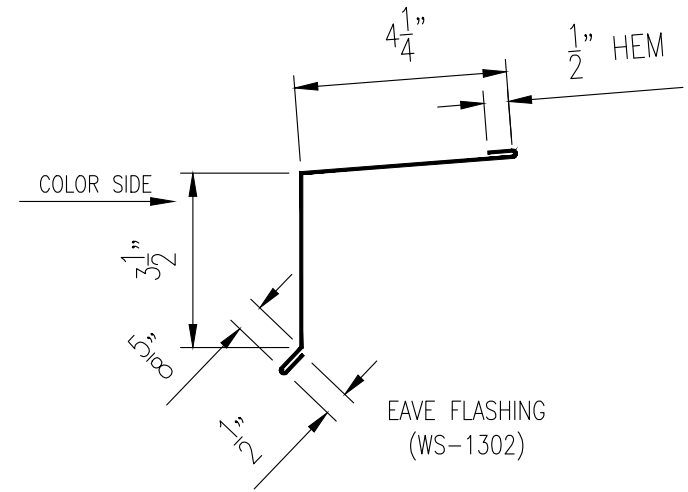
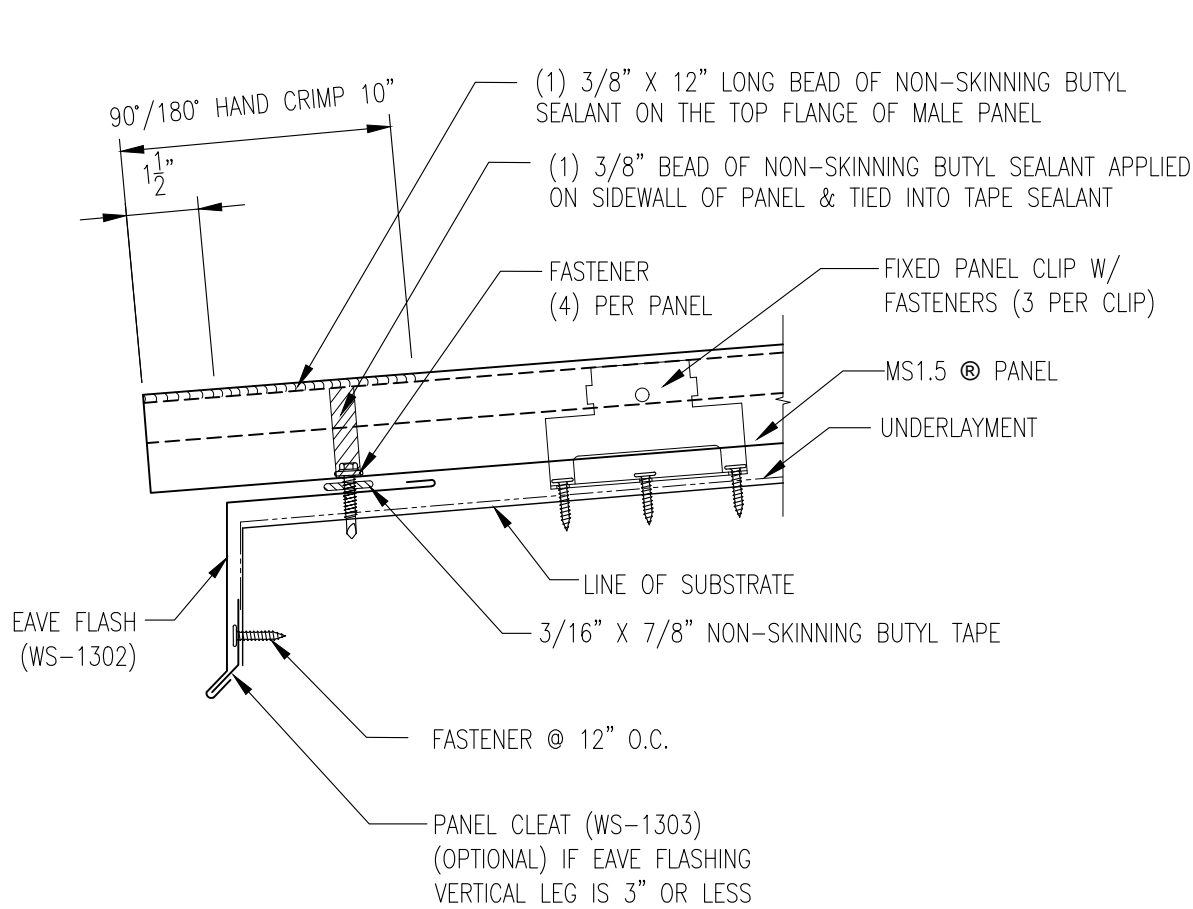

GAUGE: _____	COLOR: _____
LENGTH: _____	FINISH: _____
MATERIAL: _____	



Western States Metal Roofing

901 W. Watkins St.
Phoenix, AZ 85007
www.westernstatesmetalroofing.com

Phone: (602) 495-0048
Fax: (602) 261-7726
877-PURLINS (787-5467)



FIXED EAVE DETAIL	DATE:	
	A	11-12-25
PANEL TYPE: MS1.5® STANDING SEAM	REV:	
	DETAIL #:	MS1.5-WSD-S3

**** WSMR Recommends Sharkskin®
Ultra SA for Underlayment.**

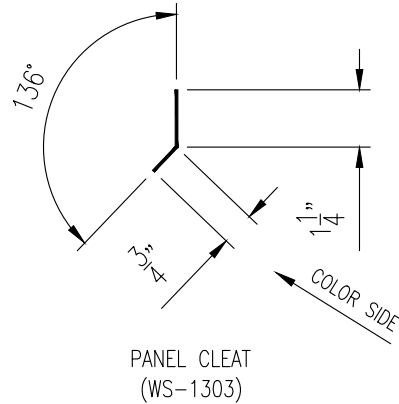
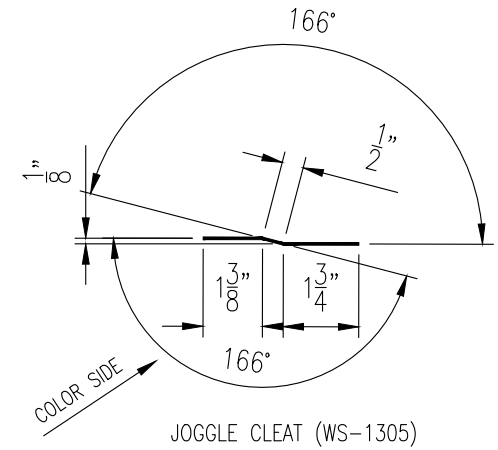
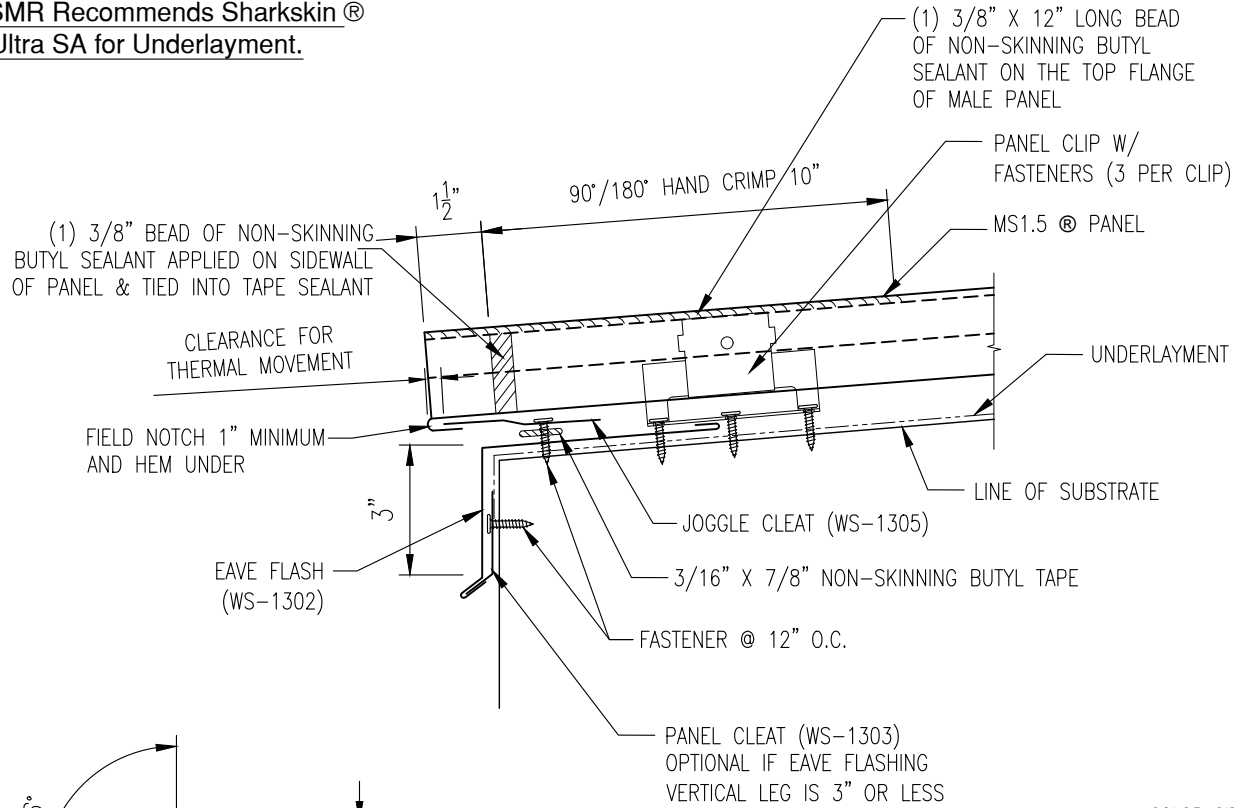

* 6" MAX CLIP PLACEMENT FROM END OF PANEL

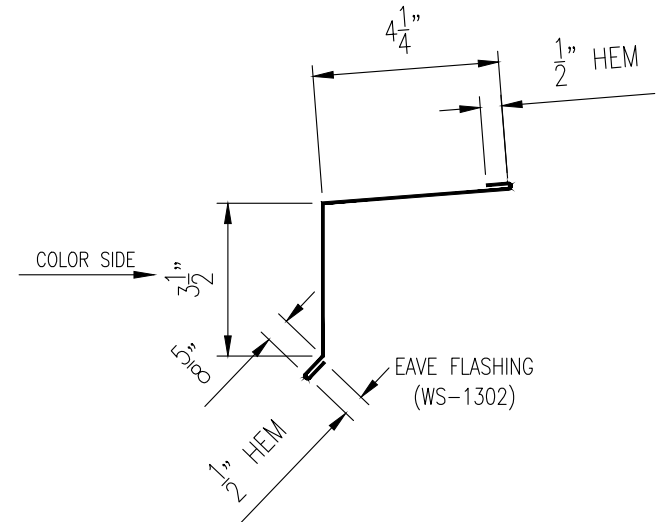

GAUGE: _____	COLOR: _____
LENGTH: _____	FINISH: _____
MATERIAL: _____	



Western States Metal Roofing

901 W. Watkins St.
Phoenix, AZ 85007
www.westernstatesmetalroofing.com

Phone: (602) 495-0048
Fax: (602) 261-7726
877-PURLINS (787-5467)



FLOATING EAVE DETAIL	DATE:	
	A	11-12-25
PANEL TYPE: MS1.5® STANDING SEAM	REV:	
	DETAIL #:	MS1.5-WSD-SW4

**** WSMR Recommends Sharkskin®
Ultra SA for Underlayment.**

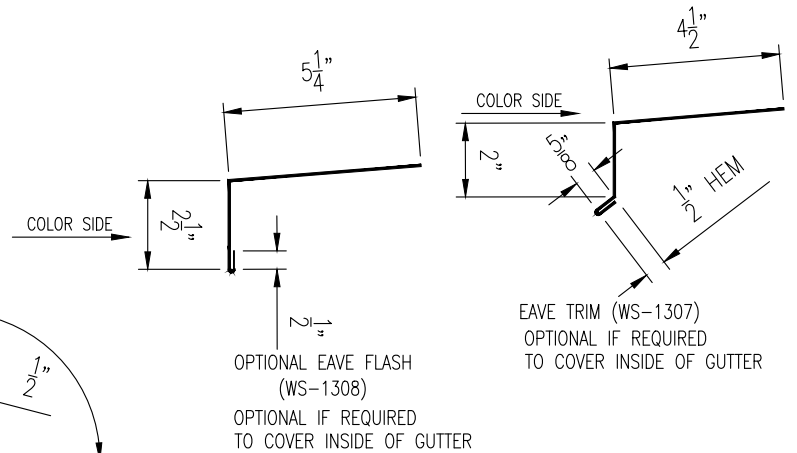
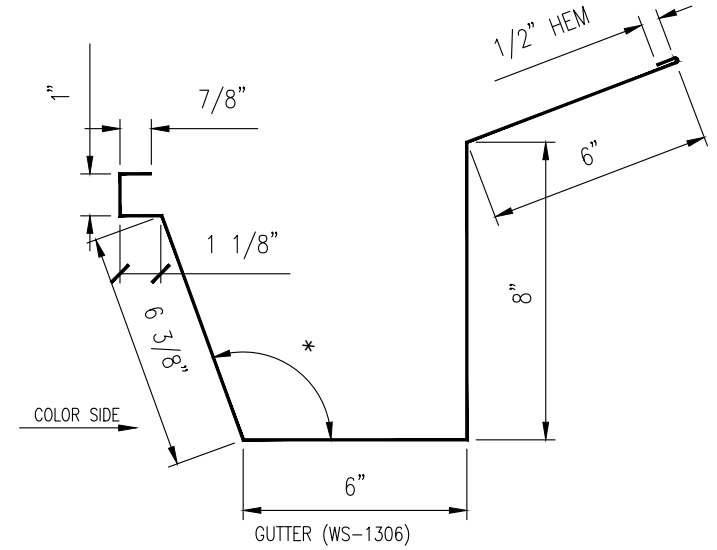
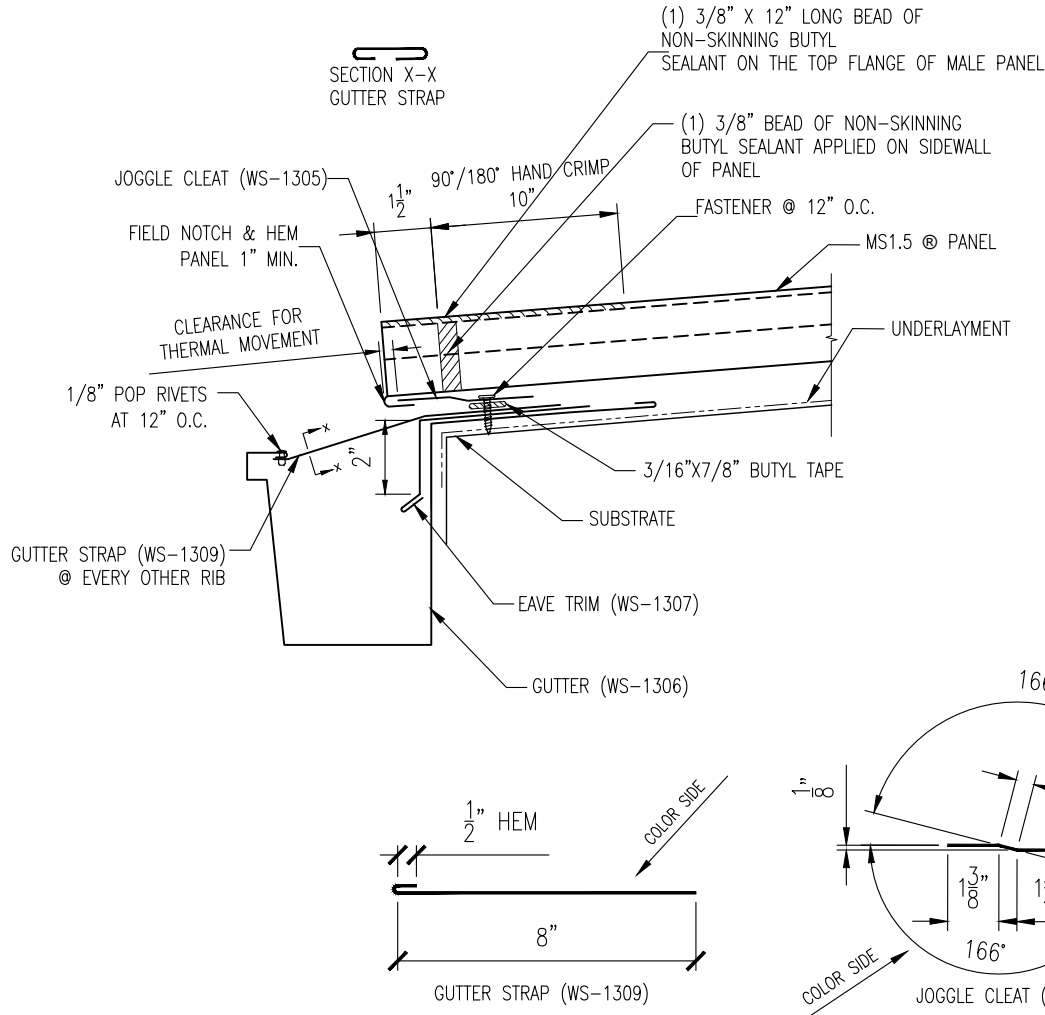

GUAGE: _____	COLOR: _____
LENGTH: _____	FINISH: _____
MATERIAL: _____	

GUTTER DETAIL	DATE:
	A 11-12-25
PANEL TYPE: MS1.5® STANDING SEAM	REV:
	DETAIL #: MS1.5-WSD-SW5



Western States Metal Roofing

901 W. Watkins St.
Phoenix, AZ 85007
www.westernstatesmetalroofing.com

Phone: (602) 495-0048
Fax: (602) 261-7726
877-PURLINS (787-5467)



* To Be Installed on Outside of Gutter

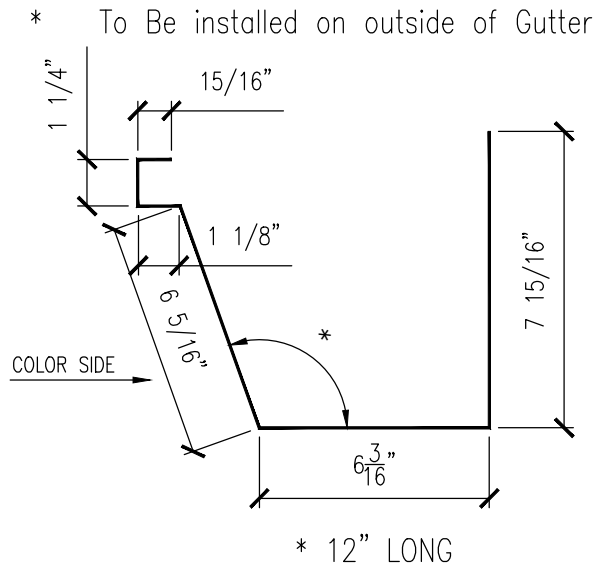
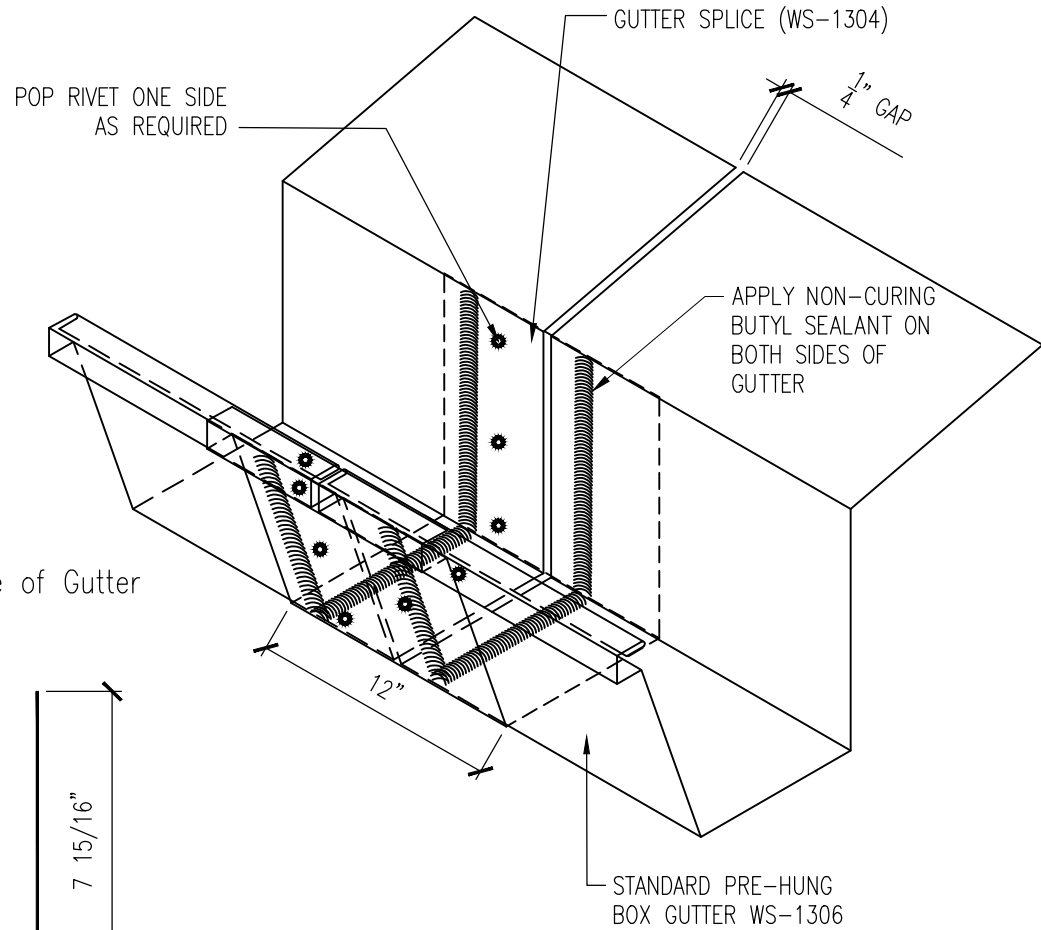

GAUGE: _____	COLOR: _____
LENGTH: _____	FINISH: _____
MATERIAL: _____	

GUTTER SPLICE DETAIL	DATE:
	A 11-12-25
PANEL TYPE: MS1.5® STANDING SEAM	REV:
	DETAIL #: MS1.5-WSD-GS6



Western States Metal Roofing

901 W. Watkins St.
Phoenix, AZ 85007
www.westernstatesmetalroofing.com

Phone: (602) 495-0048
Fax: (602) 261-7726
877-PURLINS (787-5467)



**** WSMR Recommends Sharkskin®
Ultra SA for Underlayment.**

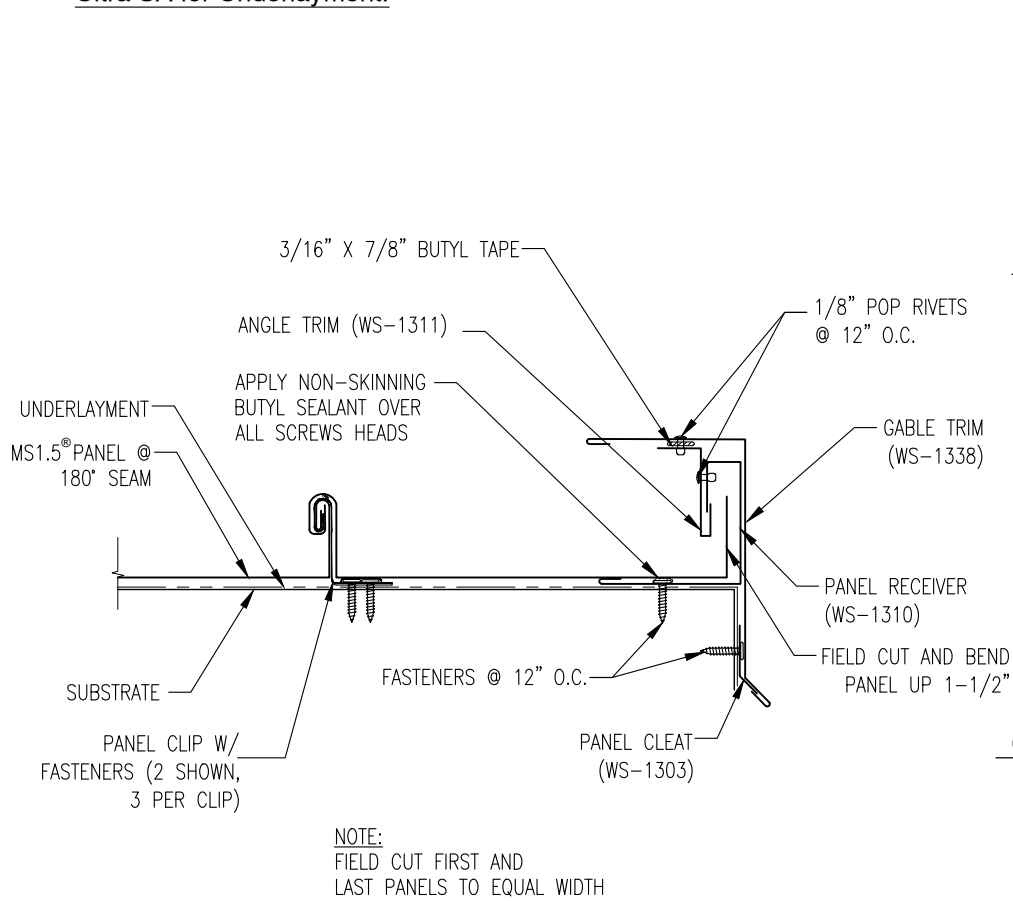

NOTE:
FIELD CUT FIRST AND
LAST PANELS TO EQUAL WIDTH

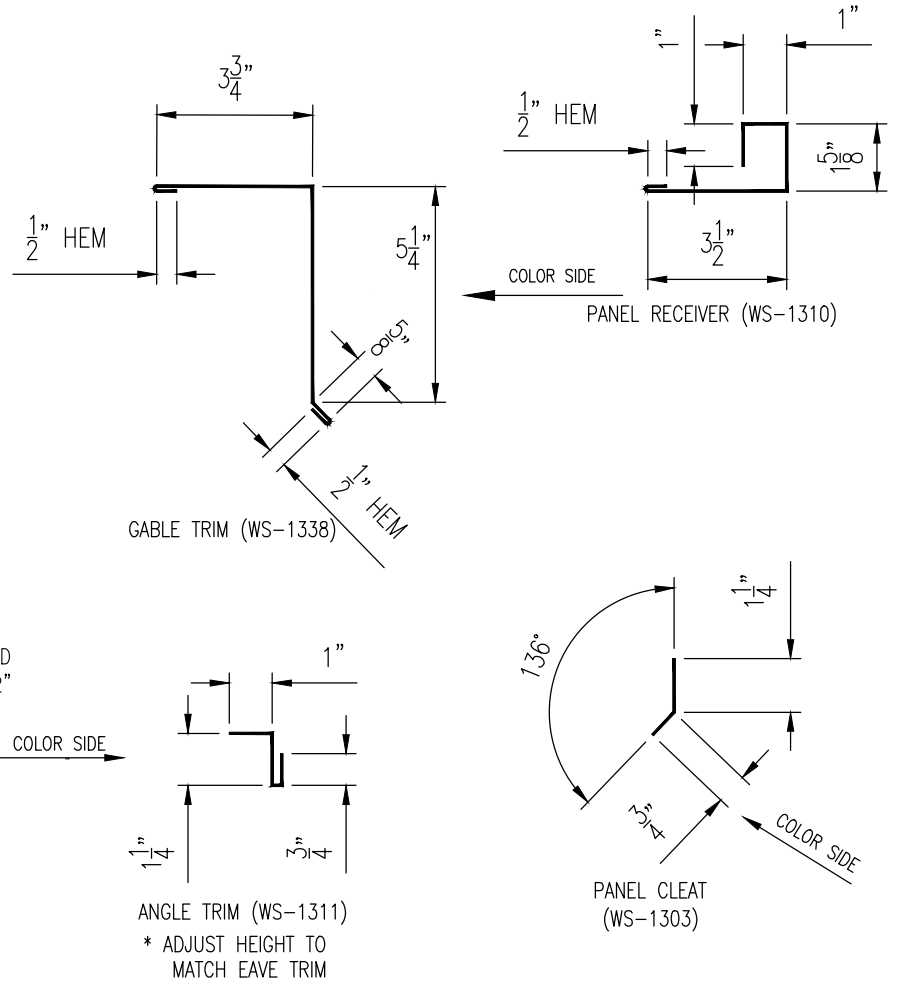

GAUGE: _____	COLOR: _____
LENGTH: _____	FINISH: _____
MATERIAL: _____	



Western States Metal Roofing

901 W. Watkins St.
Phoenix, AZ 85007
www.westernstatesmetalroofing.com

Phone: (602) 495-0048
Fax: (602) 261-7726
877-PURLINS (787-5467)



RAKE DETAIL (180° SEAM)	DATE:	
	A	11-12-25
PANEL TYPE: MS1.5® STANDING SEAM	REV:	
	DETAIL #:	MS1.5-WSD-SW7

**** WSMR Recommends Sharkskin®
Ultra SA for Underlayment.**

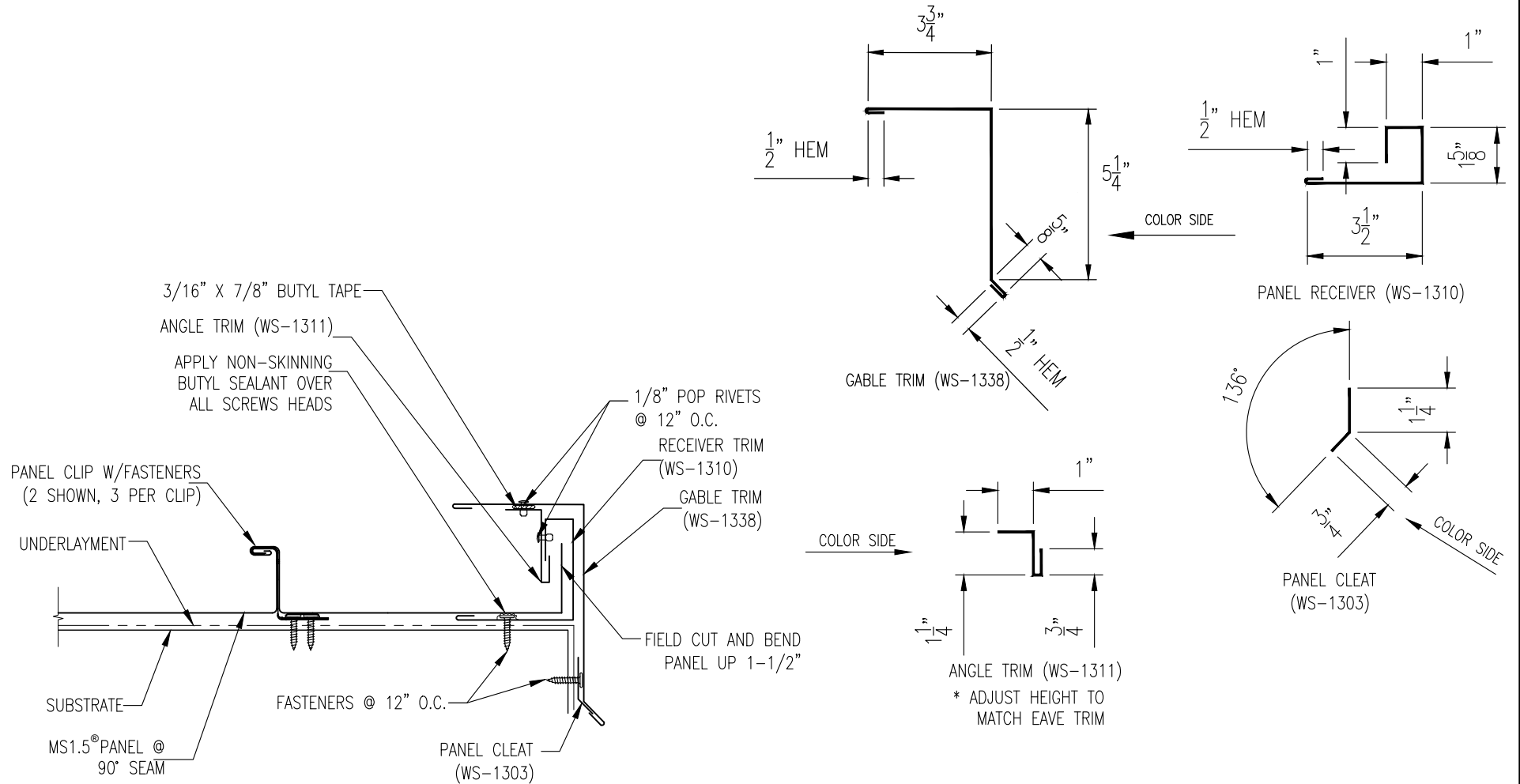

NOTE:
FIELD CUT FIRST AND
LAST PANELS TO EQUAL WIDTH

GAUGE: _____	COLOR: _____
LENGTH: _____	FINISH: _____
MATERIAL: _____	

RAKE DETAIL (90° SEAM)	DATE:
	A 11-12-25
PANEL TYPE: MS1.5® STANDING SEAM	REV:
	DETAIL #: MS1.5-WSD-SW8



Western States Metal Roofing

901 W. Watkins St.
Phoenix, AZ 85007
www.westernstatesmetalroofing.com

Phone: (602) 495-0048
Fax: (602) 261-7726
877-PURLINS (787-5467)



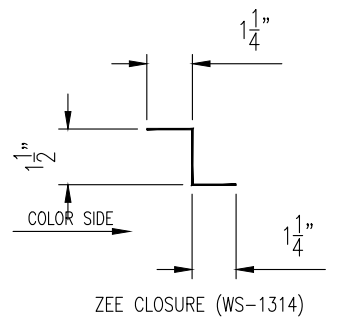
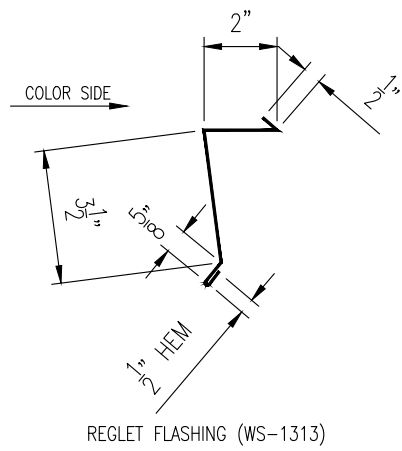
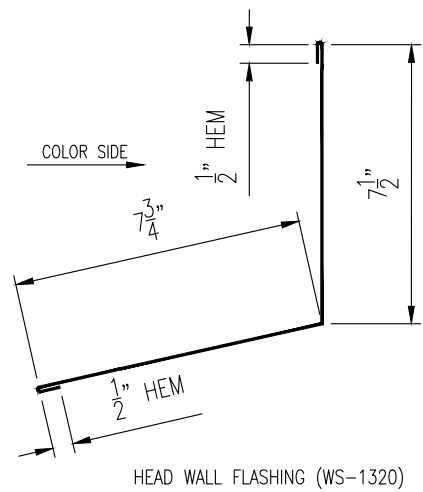
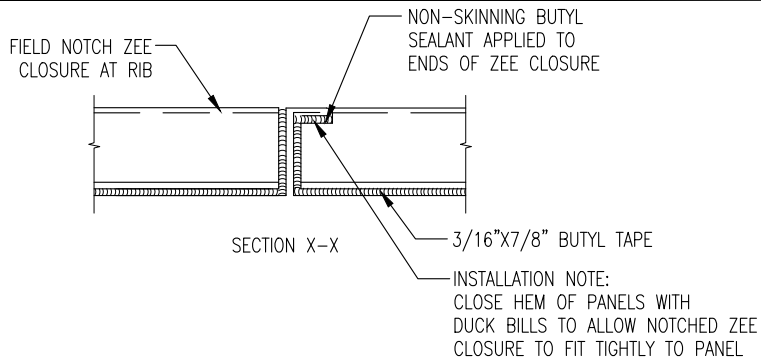

INSTALLATION NOTE:
CLOSE HEM OF PANELS WITH
DUCK BILLS TO ALLOW NOTCHED ZEE
CLOSURE TO FIT TIGHTLY TO PANEL

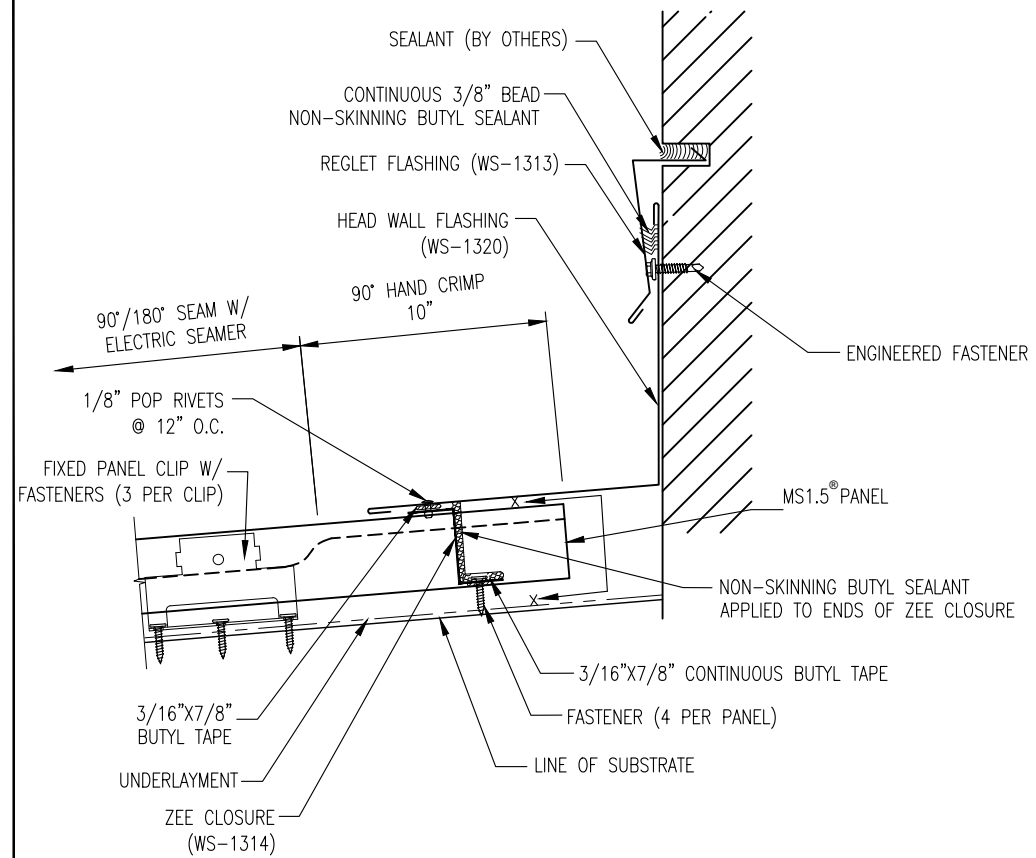

**** WSMR Recommends Sharkskin®
Ultra SA for Underlayment.**

GAUGE: _____	COLOR: _____
LENGTH: _____	FINISH: _____
MATERIAL: _____	



Western States Metal Roofing

901 W. Watkins St.
Phoenix, AZ 85007
www.westernstatesmetalroofing.com

Phone: (602) 495-0048
Fax: (602) 261-7726
877-PURLINS (787-5467)



HEAD WALL DETAIL (FIXED)	DATE:	11-12-25
	REV:	A
PANEL TYPE: MS1.5® STANDING SEAM	DETAIL #:	MS1.5-WSD-SW9

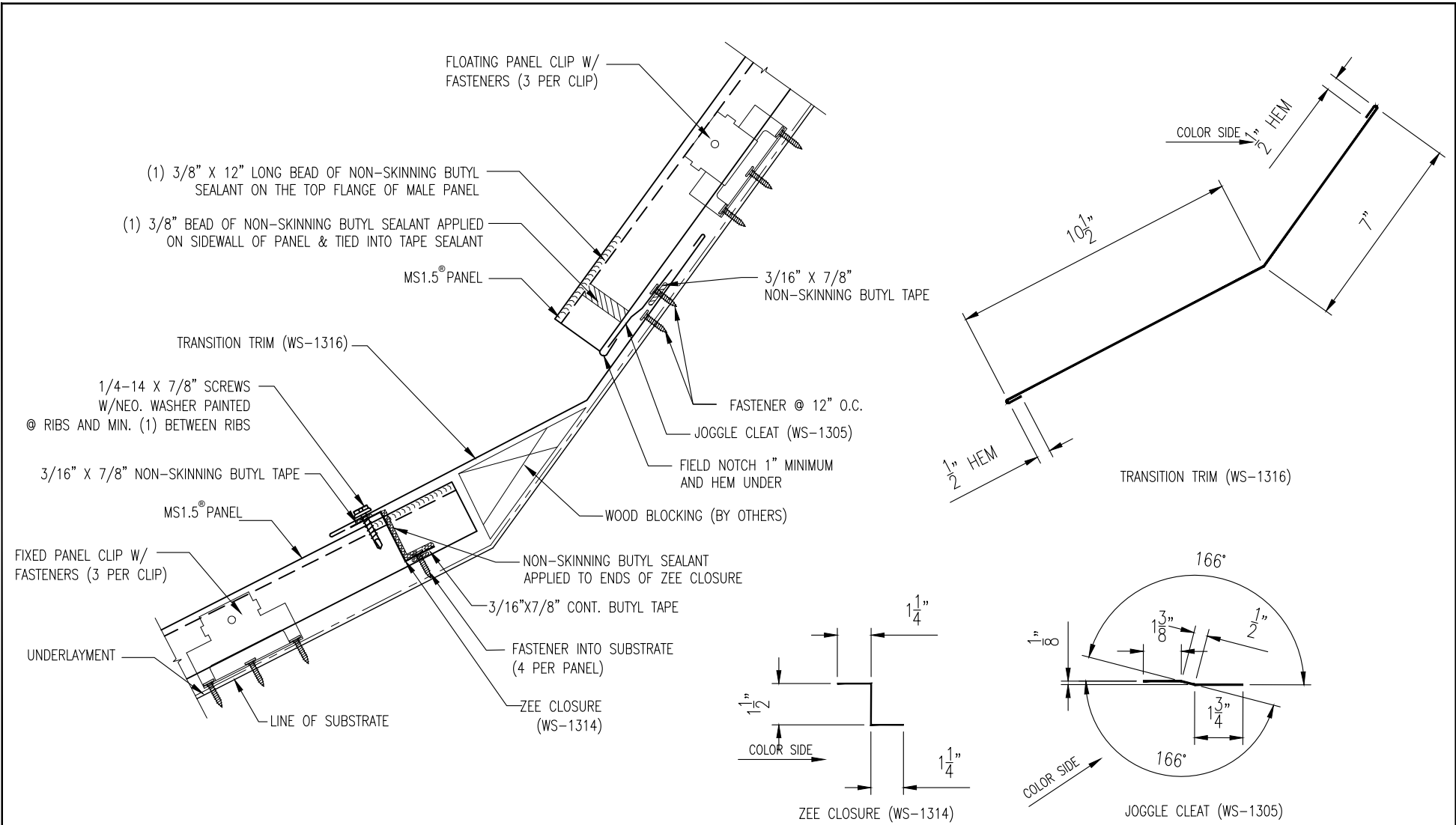

**** WSMR Recommends Sharkskin®
Ultra SA for Underlayment.**

GAUGE: _____	COLOR: _____
LENGTH: _____	FINISH: _____
MATERIAL: _____	

L/H PITCHBREAK DETAIL (FIXED)	DATE:	
	A	11-12-25
PANEL TYPE: MS1.5® STANDING SEAM	REV:	
	DETAIL #:	MS1.5-WSD-W10



Western States Metal Roofing

901 W. Watkins St.
Phoenix, AZ 85007
www.westernstatesmetalroofing.com

Phone: (602) 495-0048
Fax: (602) 261-7726
877-PURLINS (787-5467)



**** WSMR Recommends Sharkskin®
Ultra SA for Underlayment.**

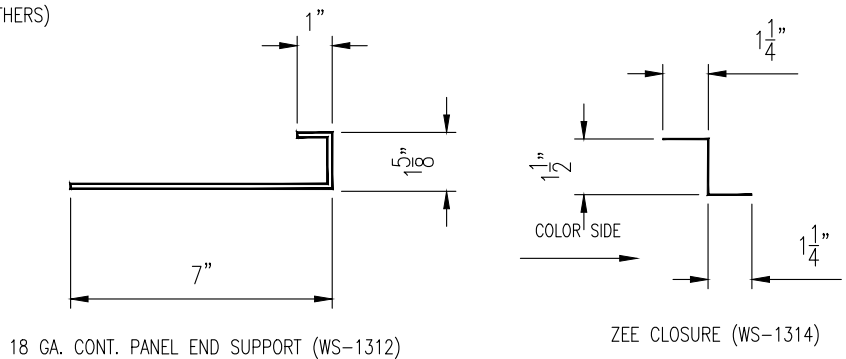
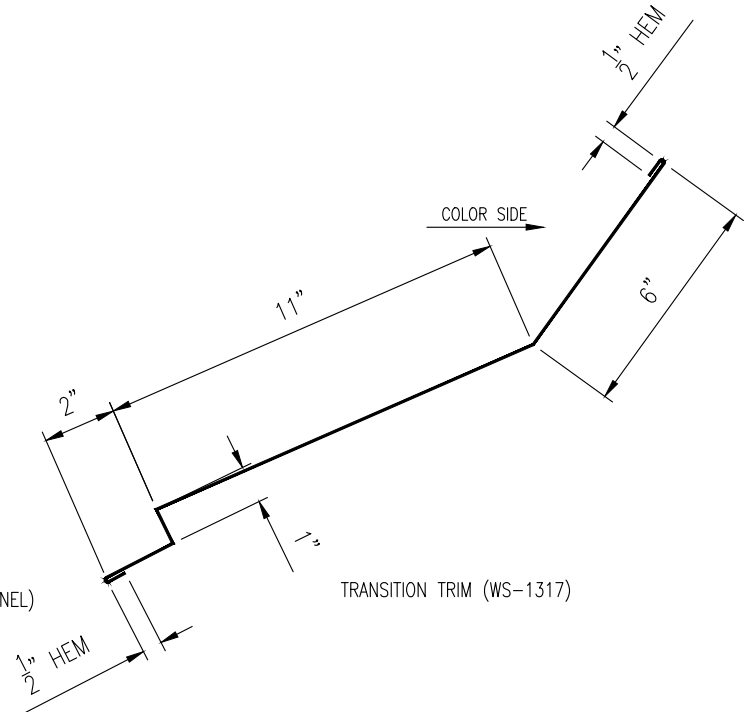
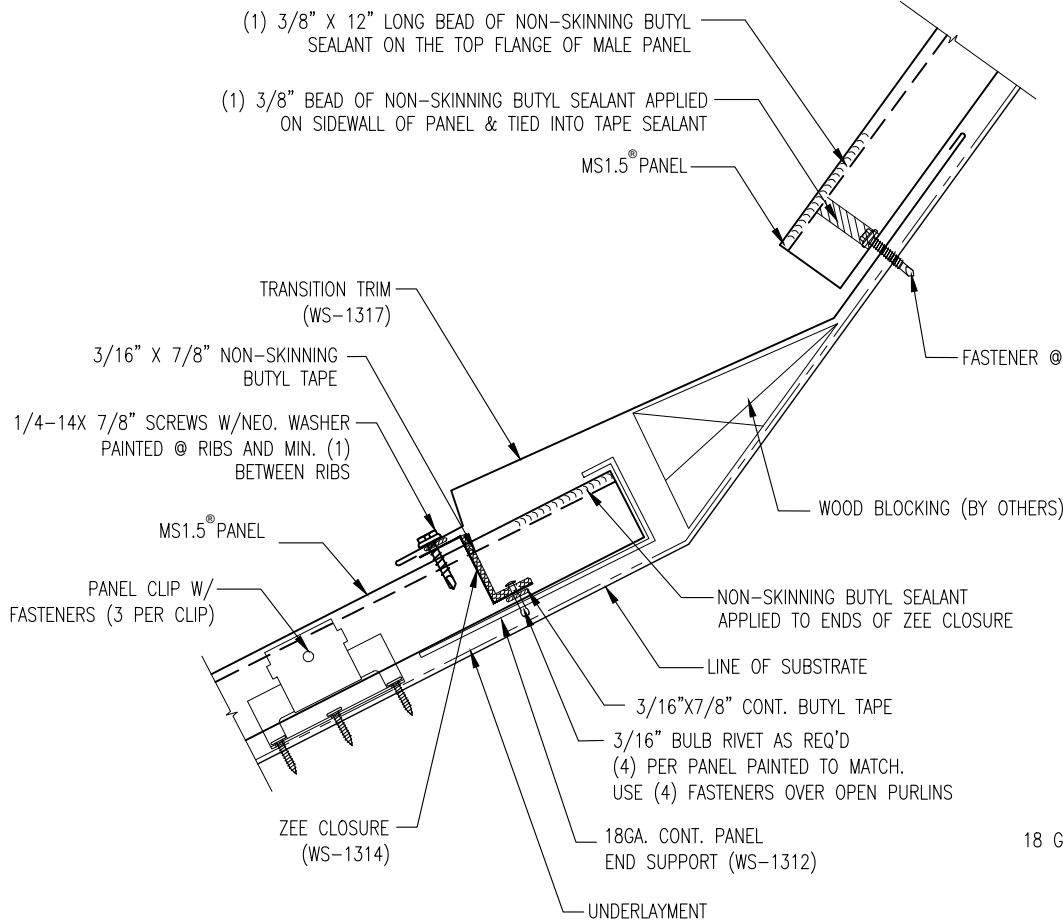

GAUGE: _____	COLOR: _____
LENGTH: _____	FINISH: _____
MATERIAL: _____	



Western States Metal Roofing

901 W. Watkins St.
Phoenix, AZ 85007
www.westernstatesmetalroofing.com

Phone: (602) 495-0048
Fax: (602) 261-7726
877-PURLINS (787-5467)



L/H PITCHBREAK DETAIL (FLOATING)	DATE:	
	A	11-12-25
PANEL TYPE: MS1.5® STANDING SEAM	REV:	
	DETAIL #:	MS1.5-WSD-W11

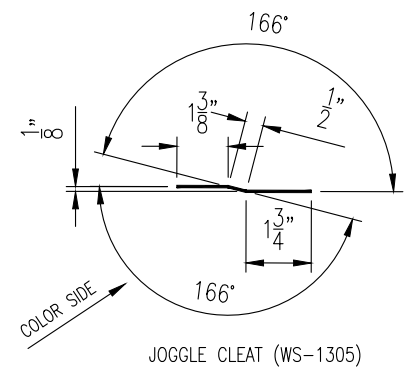
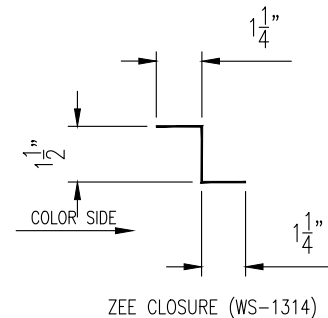
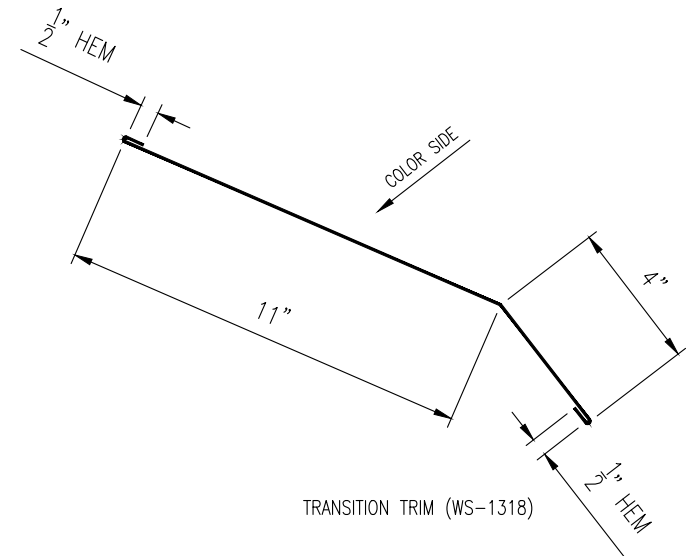
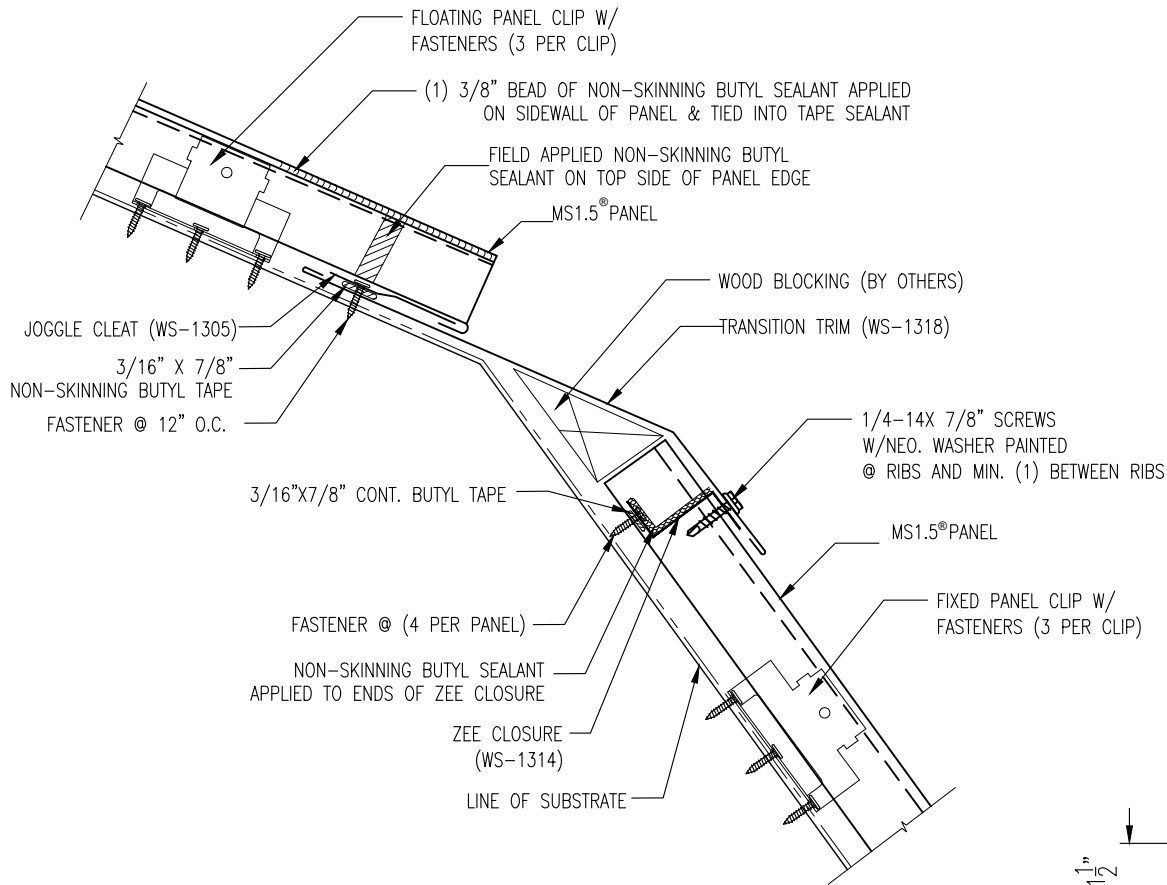

**** WSMR Recommends Sharkskin®
Ultra SA for Underlayment.**

GAUGE: _____	COLOR: _____
LENGTH: _____	FINISH: _____
MATERIAL: _____	



Western States Metal Roofing

901 W. Watkins St.
 Phoenix, AZ 85007
 www.westernstatesmetalroofing.com

Phone: (602) 495-0048
 Fax: (602) 261-7726
 877-PURLINS (787-5467)



H/L PITCHBREAK DETAIL (FIXED)	DATE:	
	A	11-12-25
PANEL TYPE: MS1.5® STANDING SEAM	REV:	
	DETAIL #:	MS1.5-WSD-W12

**** WSMR Recommends Sharkskin®
Ultra SA for Underlayment.**

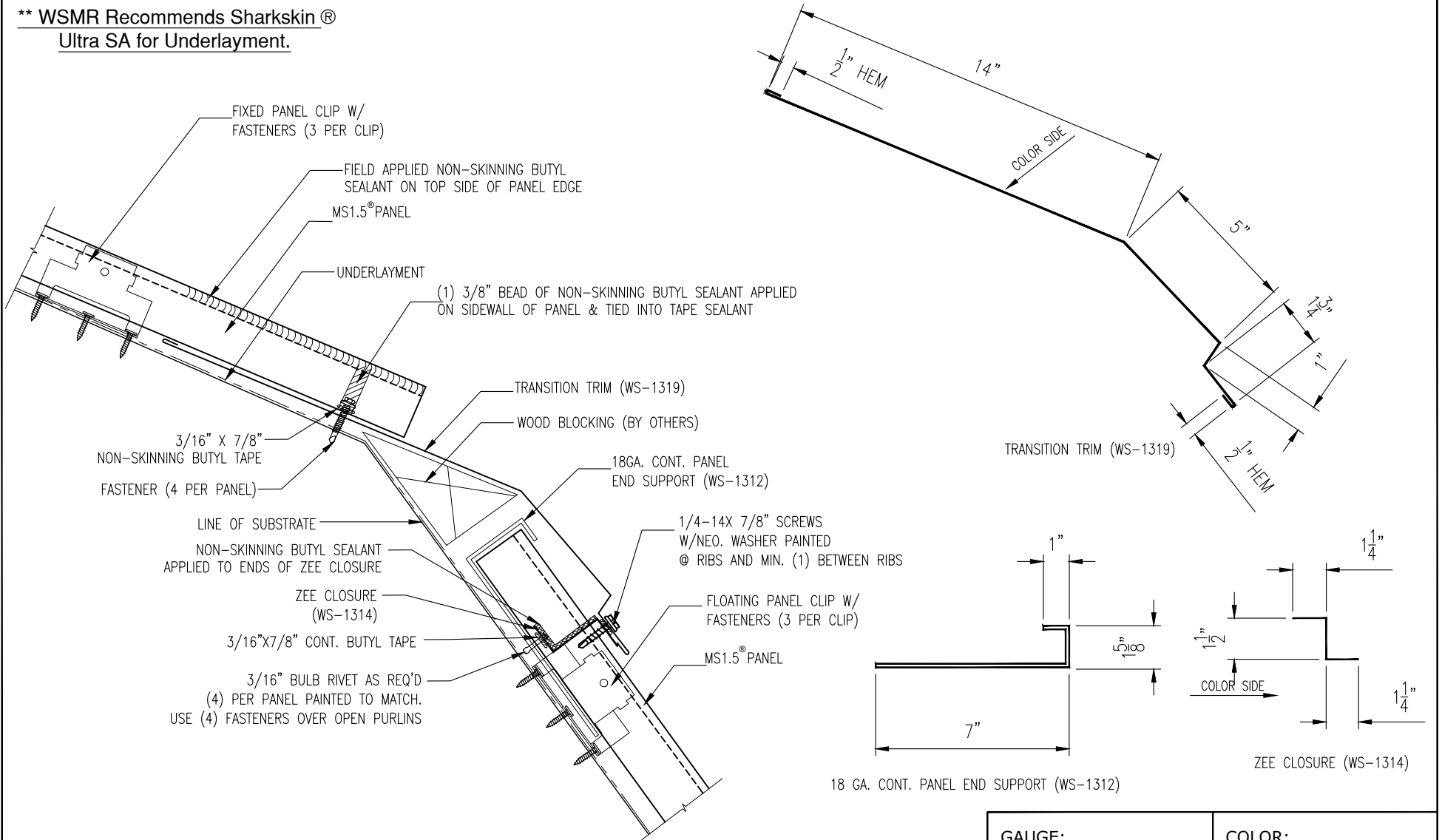

GAUGE: _____	COLOR: _____
LENGTH: _____	FINISH: _____
MATERIAL: _____	

H/L PITCHBREAK DETAIL (FLOATING)	DATE:	
	A	11-12-25
PANEL TYPE: MS1.5® STANDING SEAM	REV:	
	DETAIL #:	MS1.5-WSD-W13



Western States Metal Roofing

901 W. Watkins St.
Phoenix, AZ 85007
www.westernstatesmetalroofing.com

Phone: (602) 495-0048
Fax: (602) 261-7726
877-PURLINS (787-5467)



**** WSMR Recommends Sharkskin®
Ultra SA for Underlayment.**

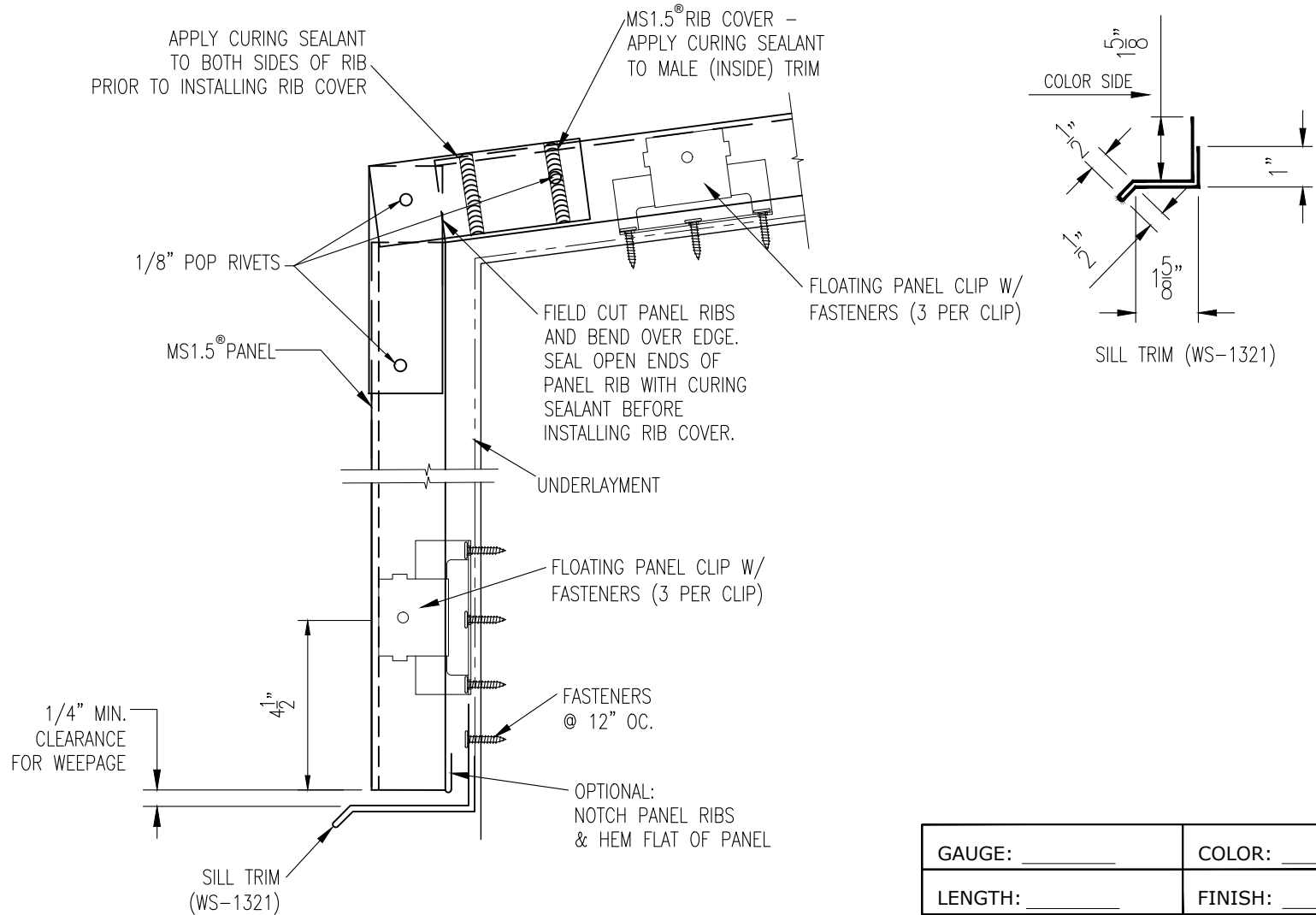

GUAGE: _____	COLOR: _____
LENGTH: _____	FINISH: _____
MATERIAL: _____	

RIB COVER DETAIL	DATE:	
	A	11-12-25
PANEL TYPE: MS1.5® STANDING SEAM	REV:	
	DETAIL #:	MS1.5-WSD-W14



Western States Metal Roofing

901 W. Watkins St.
Phoenix, AZ 85007
www.westernstatesmetalroofing.com

Phone: (602) 495-0048
Fax: (602) 261-7726
877-PURLINS (787-5467)



Western States "MS-1.5® Standing Seam" Panel

Installation, Flashings & Shop Drawing Detail Guide

MS 1.5® PANEL RIB COVER

DESIGN CAUTION:
ROOF SLOPE TRANSITIONS
SUCH AS FASCIAS MAY
ESTABLISH AN UNWANTED
POINT OF PANEL FIXITY.

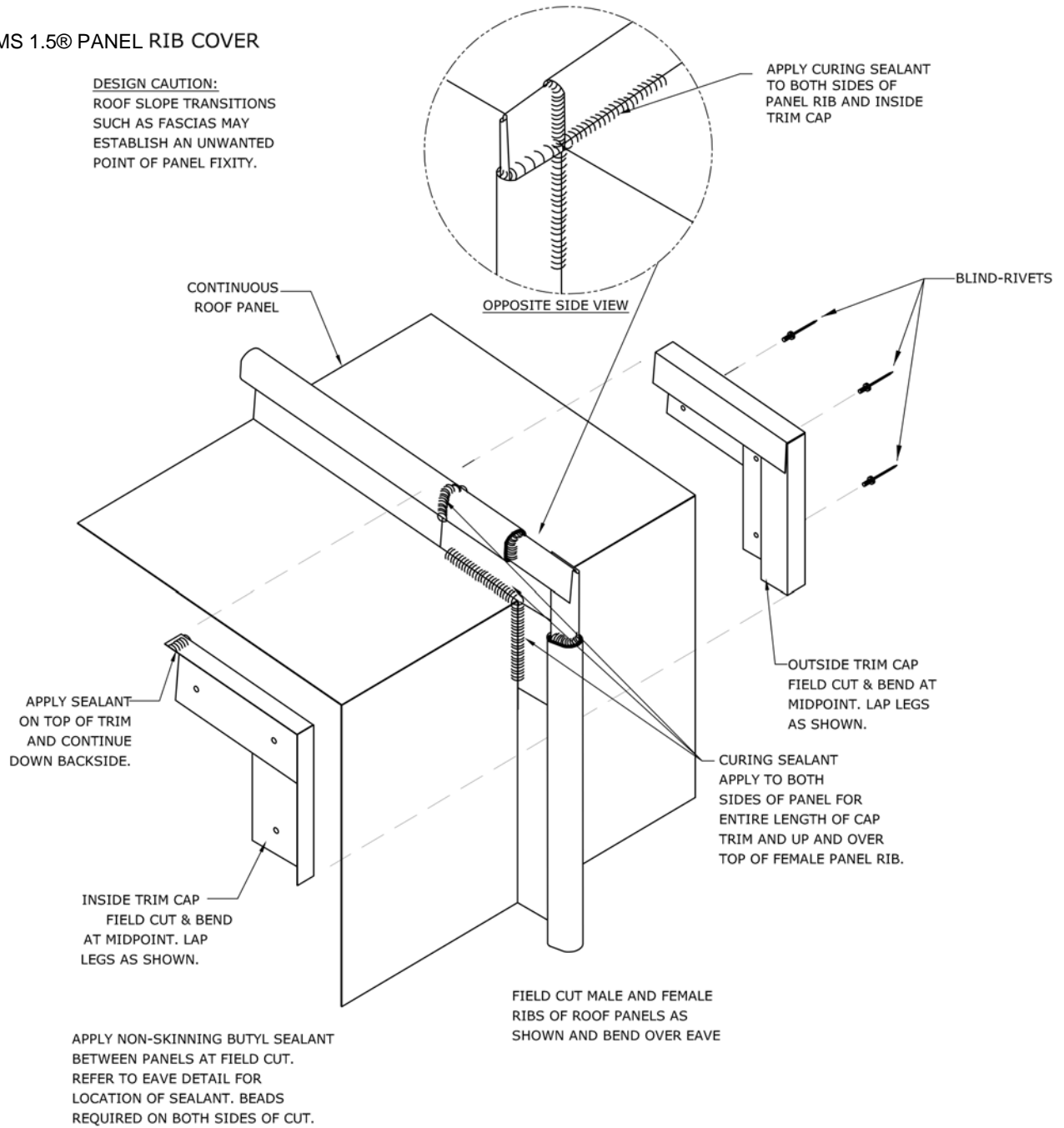

**** WSMR Recommends Sharkskin®
Ultra SA for Underlayment.**

NOTE:
FIELD CUT FIRST AND LAST
PANELS TO EQUAL WIDTH.

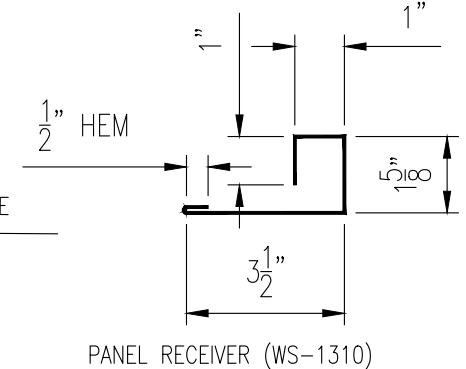
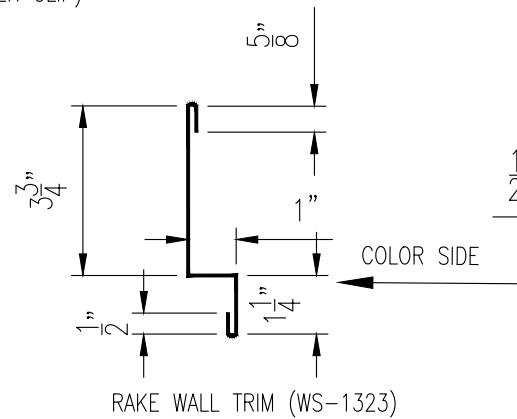
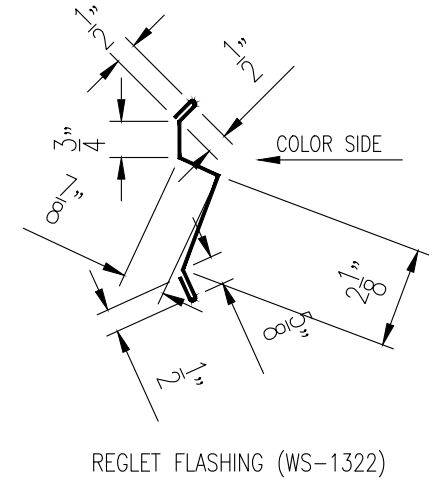
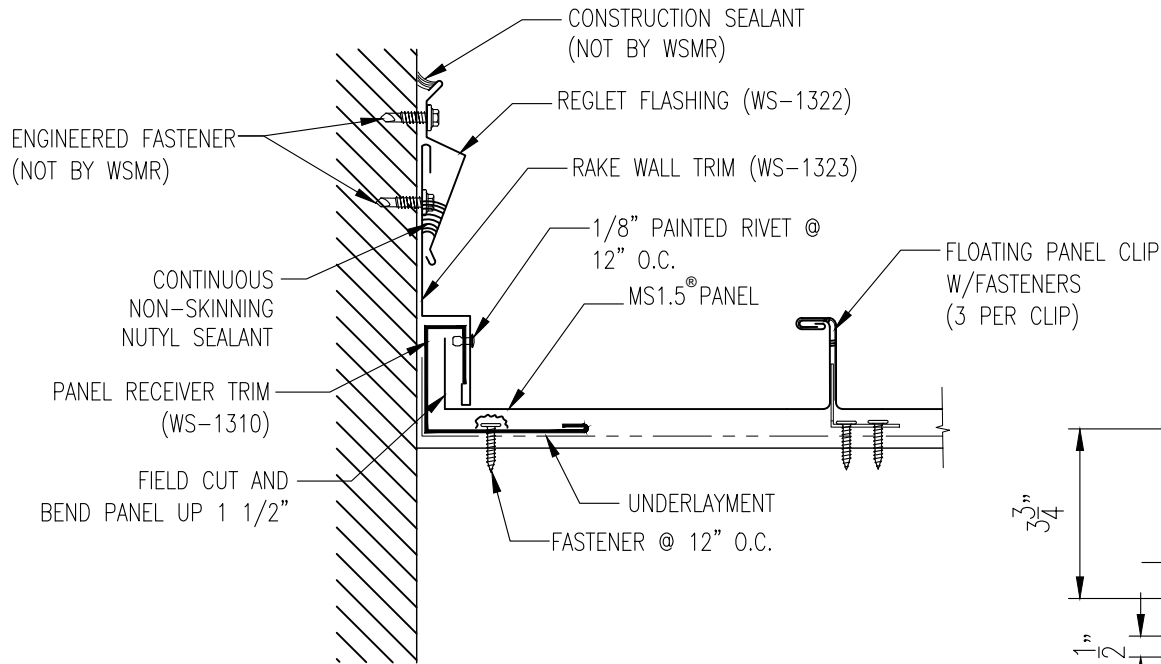

GAUGE: _____	COLOR: _____
LENGTH: _____	FINISH: _____
MATERIAL: _____	



Western States Metal Roofing

901 W. Watkins St.
Phoenix, AZ 85007
www.westernstatesmetalroofing.com

Phone: (602) 495-0048
Fax: (602) 261-7726
877-PURLINS (787-5467)



RAKE WALL DETAIL (90° SEAM)	DATE:	
	A	11-12-25
PANEL TYPE: MS1.5® STANDING SEAM	REV:	
	DETAIL #:	MS1.5-WSD-W15

**** WSMR Recommends Sharkskin®
Ultra SA for Underlayment.**

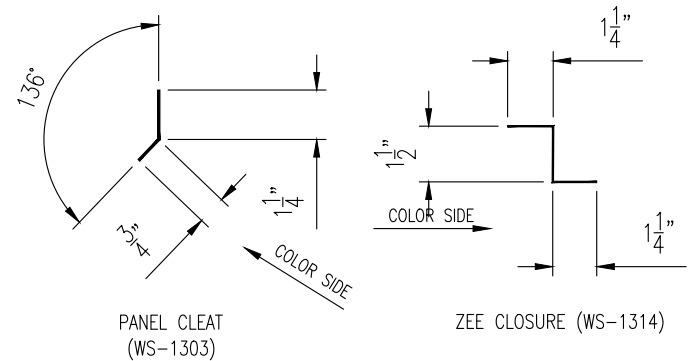
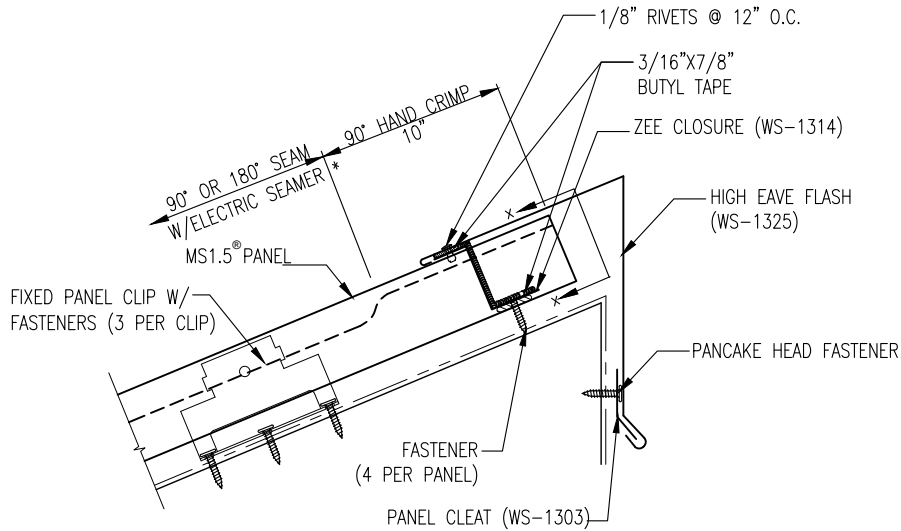
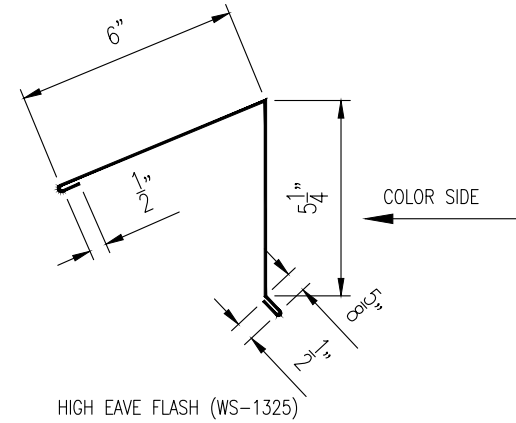
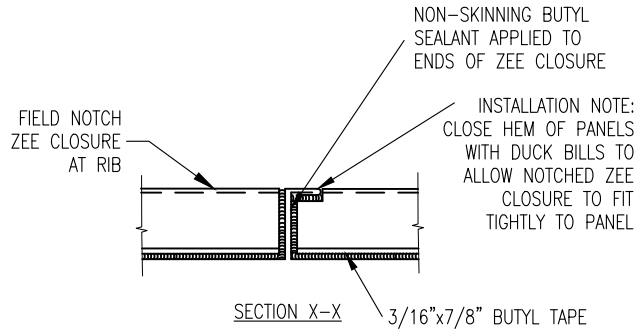

GAUGE: _____	COLOR: _____
LENGTH: _____	FINISH: _____
MATERIAL: _____	

HIGH EAVE DETAIL (FIXED)	DATE:	
	A	11-12-25
PANEL TYPE: MS1.5® STANDING SEAM	REV:	
	DETAIL #:	MS1.5-WSD-W17



Western States Metal Roofing

901 W. Watkins St.
Phoenix, AZ 85007
www.westernstatesmetalroofing.com

Phone: (602) 495-0048
Fax: (602) 261-7726
877-PURLINS (787-5467)



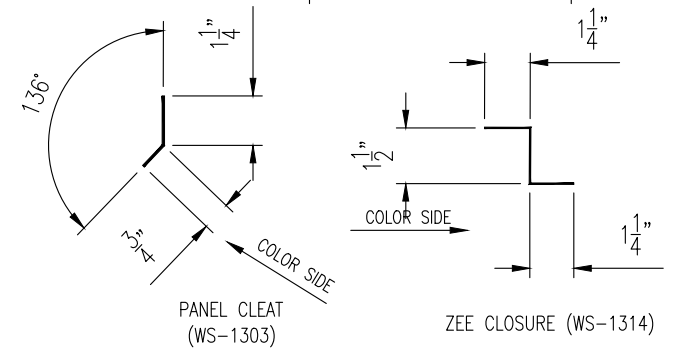
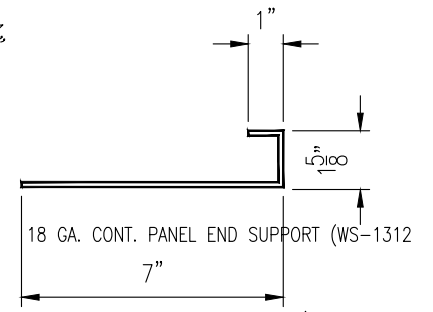
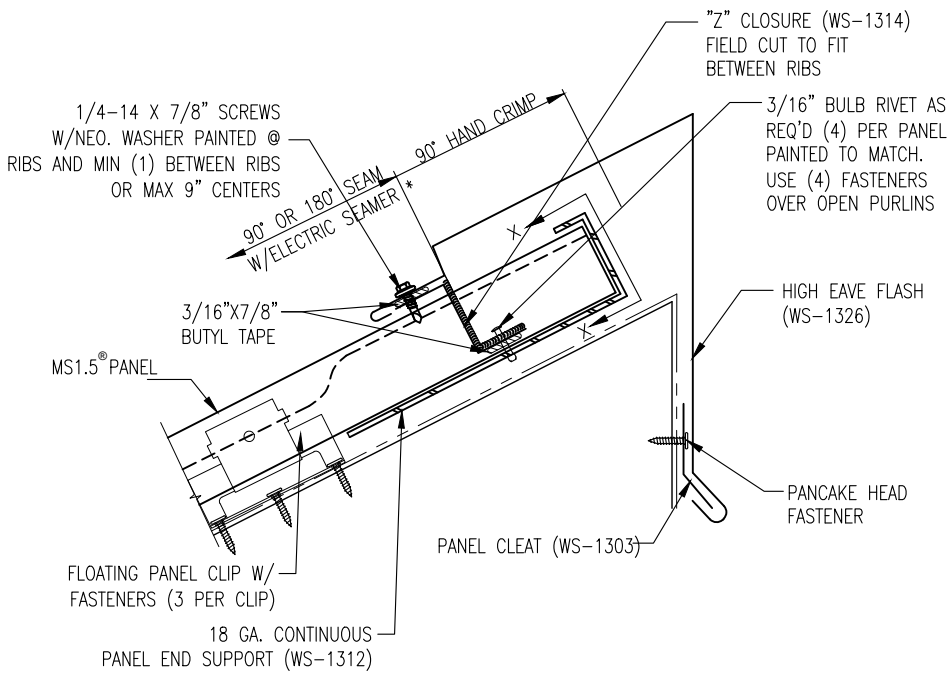
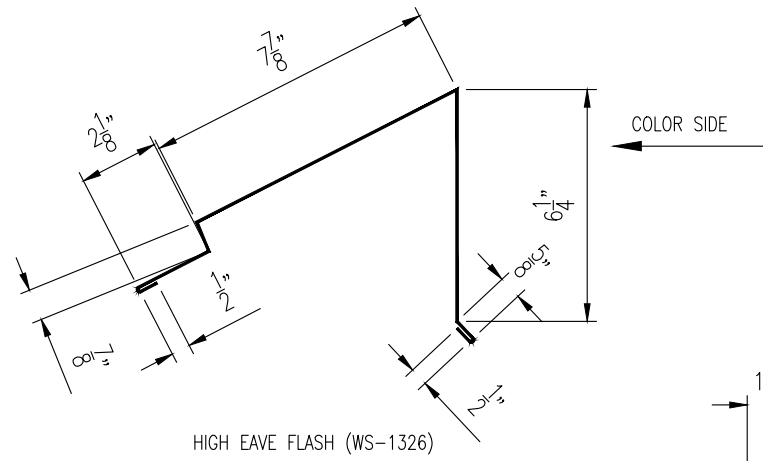
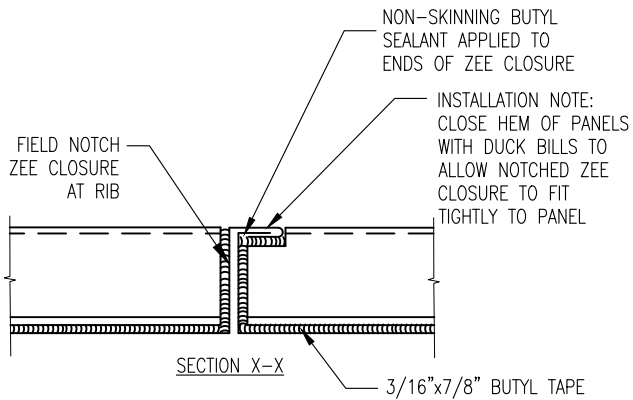

**** WSMR Recommends Sharkskin®
Ultra SA for Underlayment.**



Western States Metal Roofing

901 W. Watkins St.
Phoenix, AZ 85007
www.westernstatesmetalroofing.com

Phone: (602) 495-0048
Fax: (602) 261-7726
877-PURLINS (787-5467)



GAUGE: _____		COLOR: _____	
LENGTH: _____		FINISH: _____	
MATERIAL: _____			
HIGH EAVE DETAIL (FLOATING)		DATE:	
		A	11-12-25
PANEL TYPE: MS1.5® STANDING SEAM		REV: _____	
		DETAIL #: MS1.5-WSD-W18	

**** WSMR Recommends Sharkskin®
Ultra SA for Underlayment.**

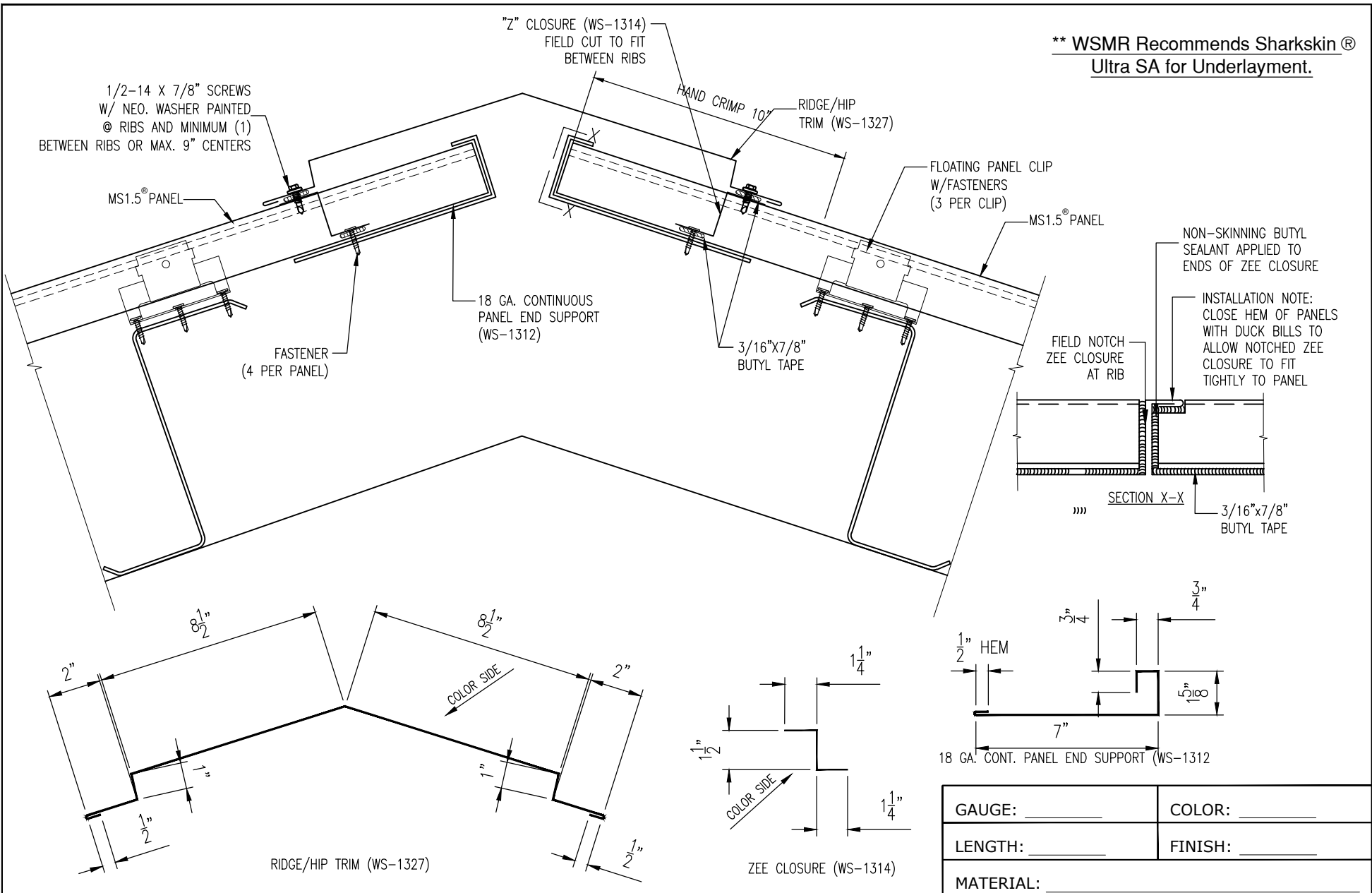

GAUGE: _____	COLOR: _____
LENGTH: _____	FINISH: _____
MATERIAL: _____	

RIDGE DETAIL (FLOATING)	DATE:	
	A	11-12-25
PANEL TYPE: MS1.5® STANDING SEAM	REV:	
	DETAIL #:	MS1.5-WSD-W19



Western States Metal Roofing

901 W. Watkins St.
Phoenix, AZ 85007
www.westernstatesmetalroofing.com

Phone: (602) 495-0048
Fax: (602) 261-7726
877-PURLINS (787-5467)



**** WSMR Recommends Sharkskin®
Ultra SA for Underlayment.**

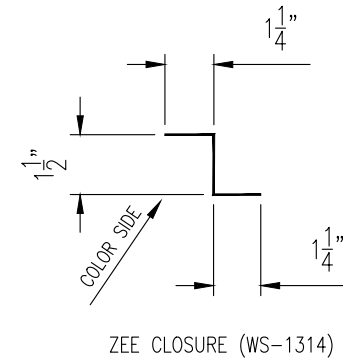
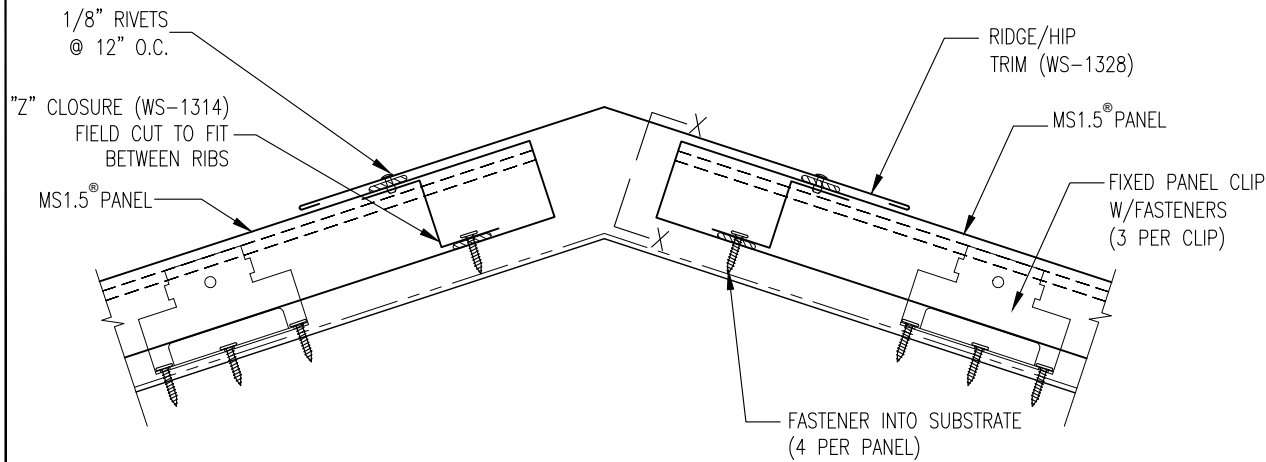
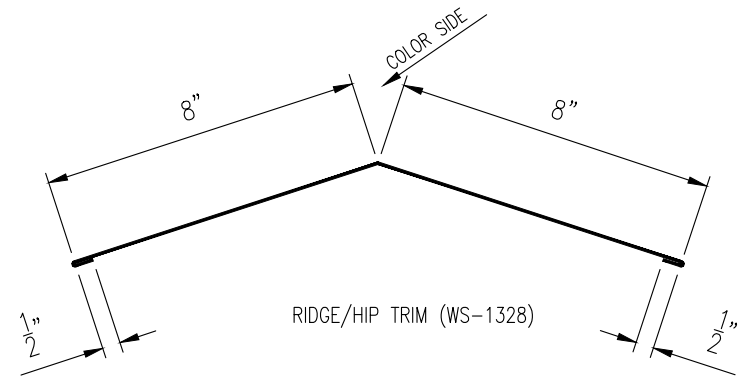
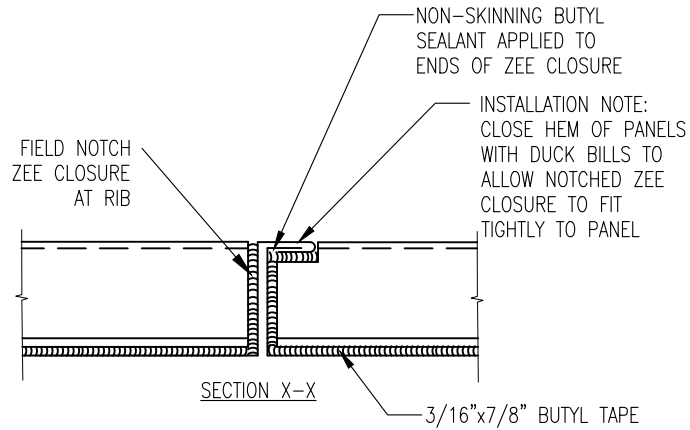

GAUGE: _____	COLOR: _____
LENGTH: _____	FINISH: _____
MATERIAL: _____	



Western States Metal Roofing

901 W. Watkins St.
Phoenix, AZ 85007
www.westernstatesmetalroofing.com

Phone: (602) 495-0048
Fax: (602) 261-7726
877-PURLINS (787-5467)



RIDGE DETAIL (FIXED)	DATE:	
	A	11-12-25
PANEL TYPE: MS1.5® STANDING SEAM	REV:	
	DETAIL #:	MS1.5-WSD-W20

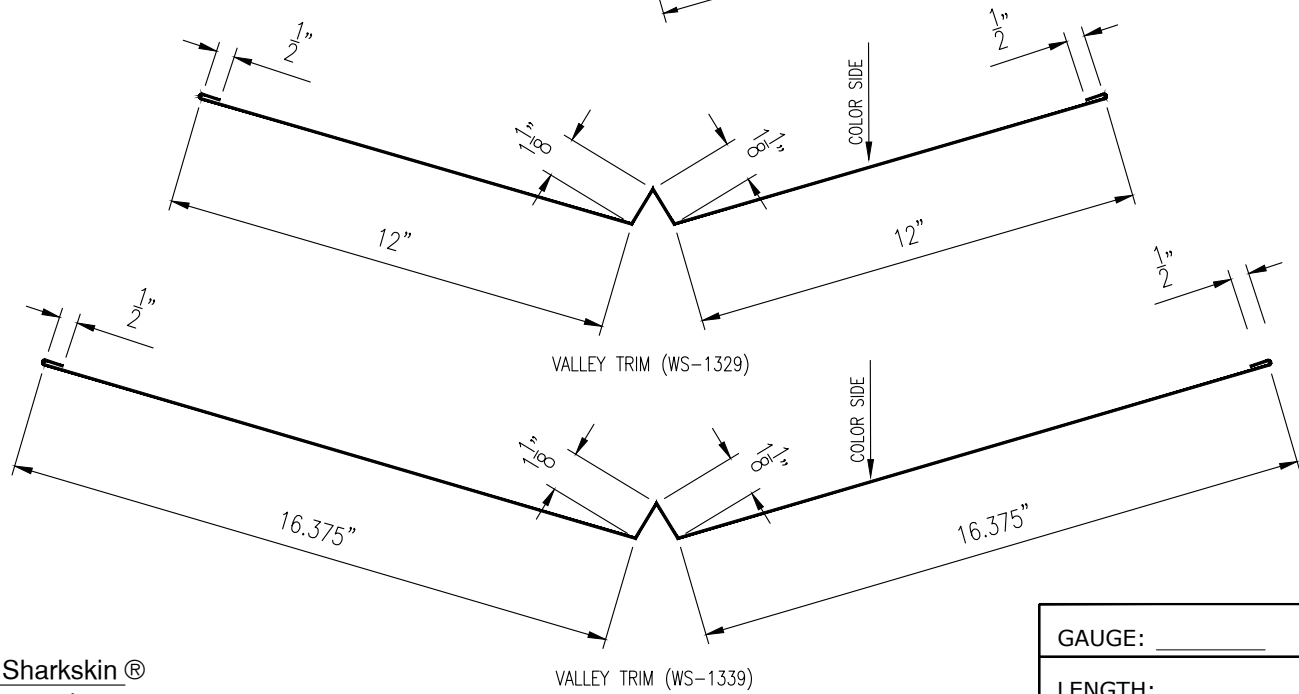
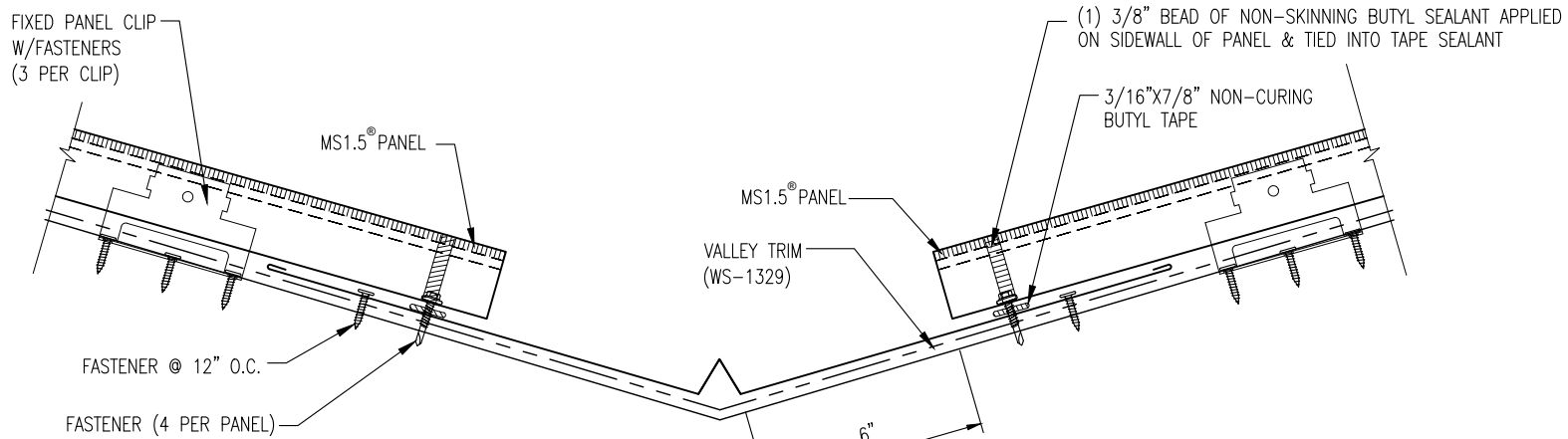

** WSMR Recommends Sharkskin[®] Ultra SA for Underlayment.

GAUGE: _____	COLOR: _____
LENGTH: _____	FINISH: _____
MATERIAL: _____	



Western States Metal Roofing

901 W. Watkins St.
Phoenix, AZ 85007
www.westernstatesmetalroofing.com

Phone: (602) 495-0048
Fax: (602) 261-7726
877-PURLINS (787-5467)



VALLEY DETAIL (FIXED)	DATE:	
	A	11-12-25
PANEL TYPE: MS1.5 [®] STANDING SEAM	REV:	
	DETAIL #:	MS1.5-WSD-W21

**** WSMR Recommends Sharkskin® Ultra SA for Underlayment.**

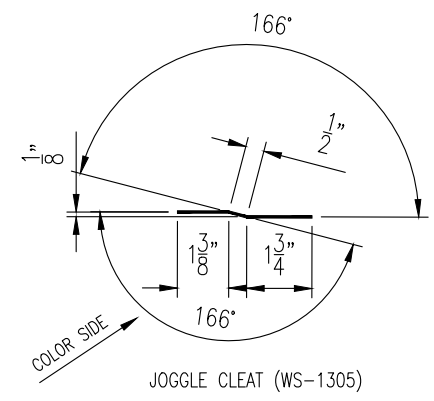
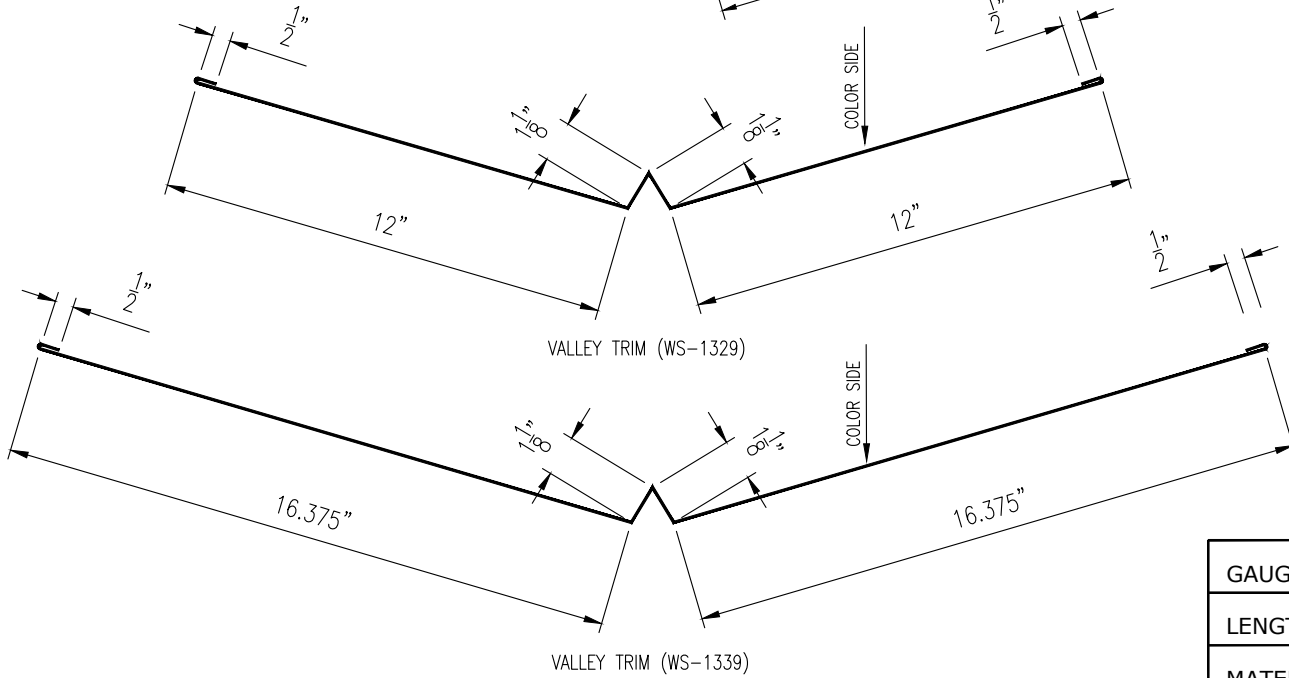
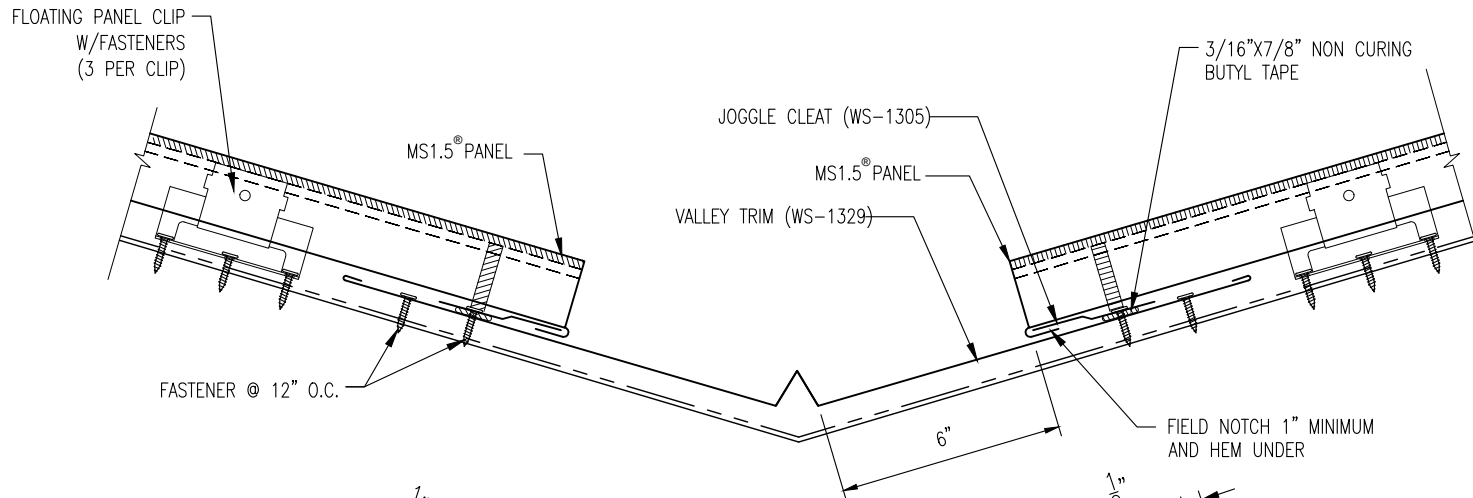

GAUGE: _____	COLOR: _____
LENGTH: _____	FINISH: _____
MATERIAL: _____	



Western States Metal Roofing

901 W. Watkins St.
Phoenix, AZ 85007
www.westernstatesmetalroofing.com

Phone: (602) 495-0048
Fax: (602) 261-7726
877-PURLINS (787-5467)



VALLEY DETAIL (FLOATING)	DATE:	
	A	11-12-25
PANEL TYPE: MS1.5® STANDING SEAM	REV:	
	DETAIL #:	MS1.5-WSD-W22

**** WSMR Recommends Sharkskin®
Ultra SA for Underlayment.**

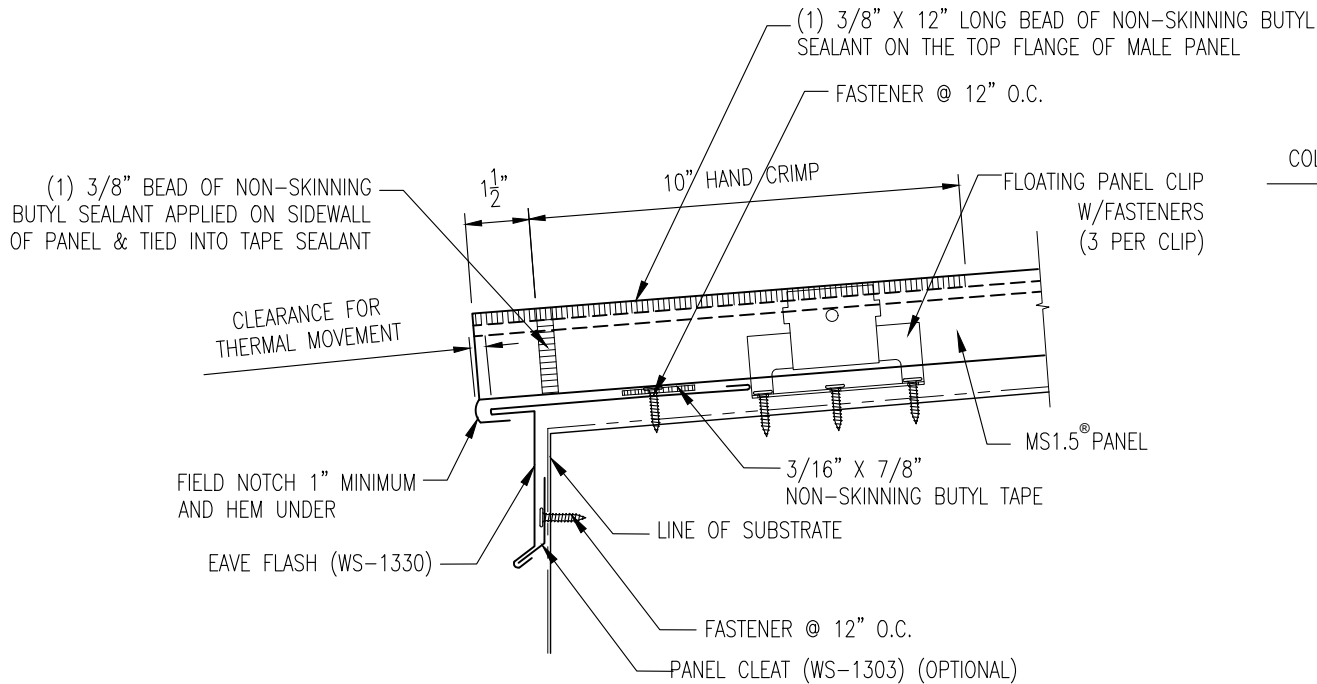

* 6" MAX CLIP PLACEMENT FROM END OF PANEL

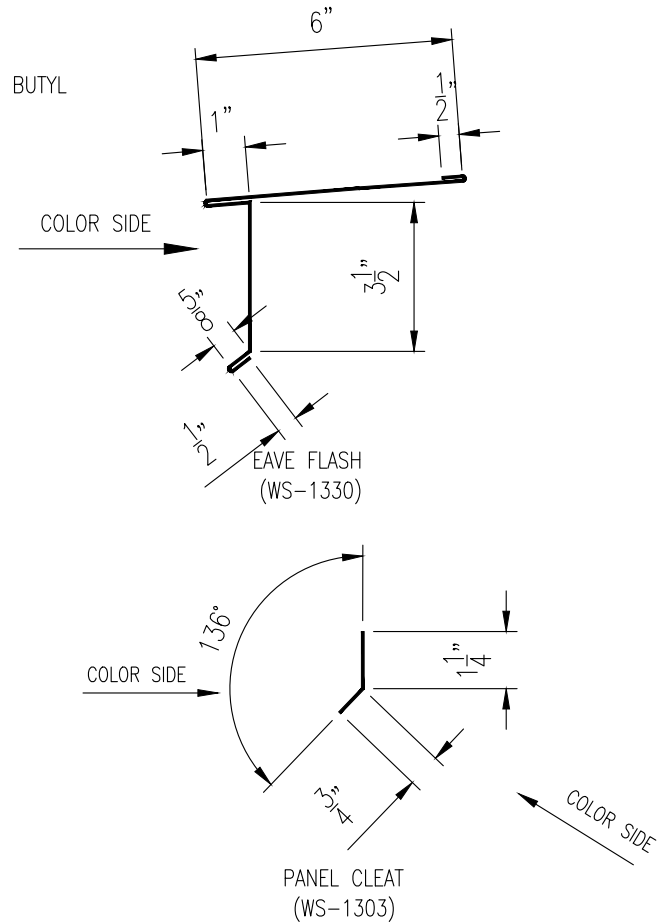

GAUGE: _____	COLOR: _____
LENGTH: _____	FINISH: _____
MATERIAL: _____	



Western States Metal Roofing

901 W. Watkins St.
Phoenix, AZ 85007
www.westernstatesmetalroofing.com

Phone: (602) 495-0048
Fax: (602) 261-7726
877-PURLINS (787-5467)



BULL NOSE EAVE DETAIL	DATE:	
	A	11-12-25
PANEL TYPE: MS1.5® STANDING SEAM	REV:	
	DETAIL #:	MS1.5-WSD-W23

**** WSMR Recommends Sharkskin®
Ultra SA for Underlayment.**

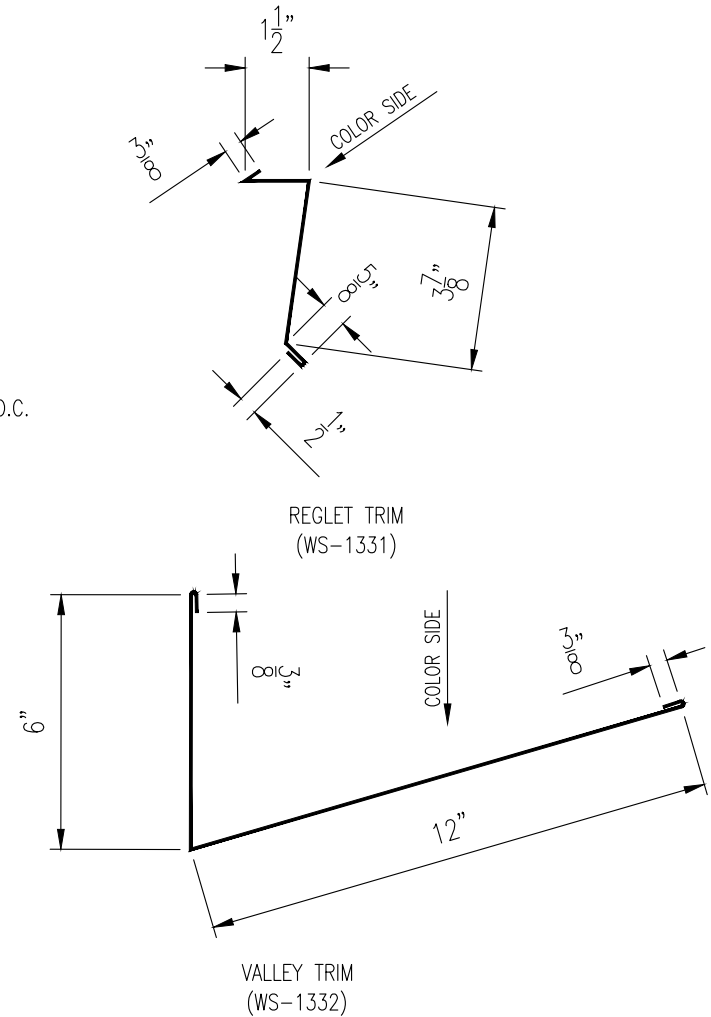
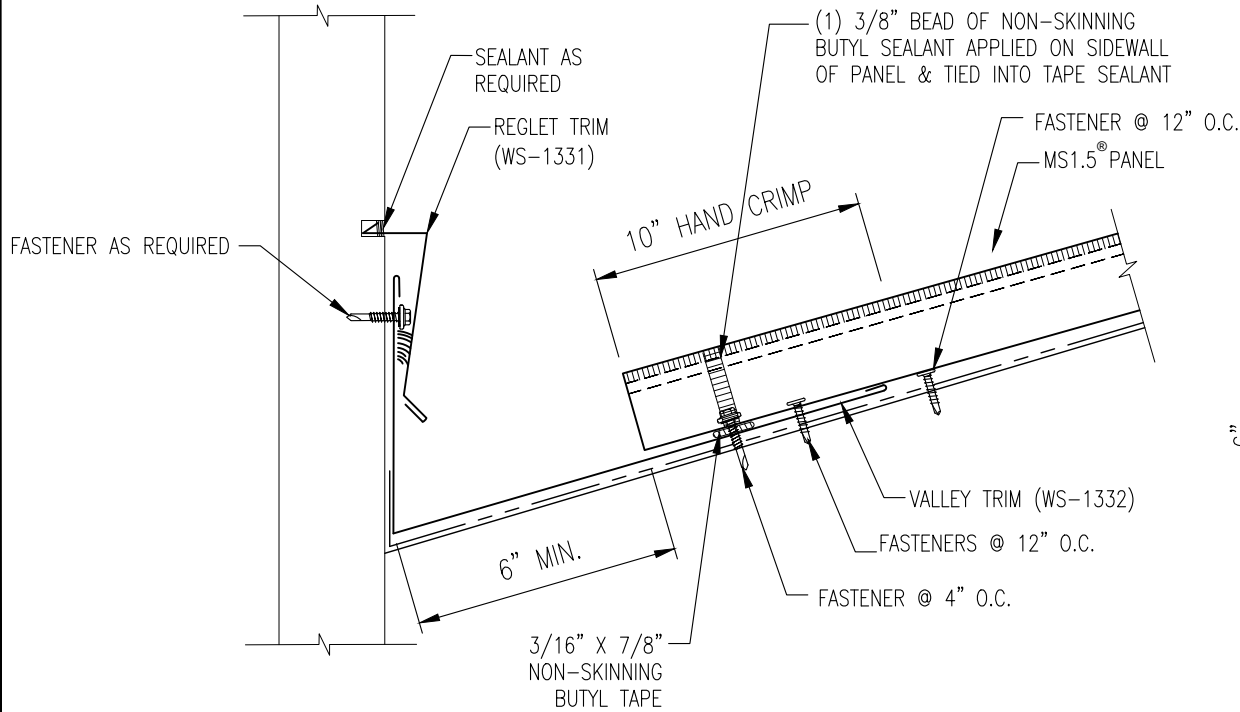

GAUGE: _____	COLOR: _____
LENGTH: _____	FINISH: _____
MATERIAL: _____	



Western States Metal Roofing

901 W. Watkins St.
Phoenix, AZ 85007
www.westernstatesmetalroofing.com

Phone: (602) 495-0048
Fax: (602) 261-7726
877-PURLINS (787-5467)



HALF VALLEY DETAIL (FIXED)	DATE:	
	A	11-12-25
PANEL TYPE: MS1.5® STANDING SEAM	REV:	
	DETAIL #:	MS1.5-WSD-W24

**** WSMR Recommends Sharkskin®
Ultra SA for Underlayment.**

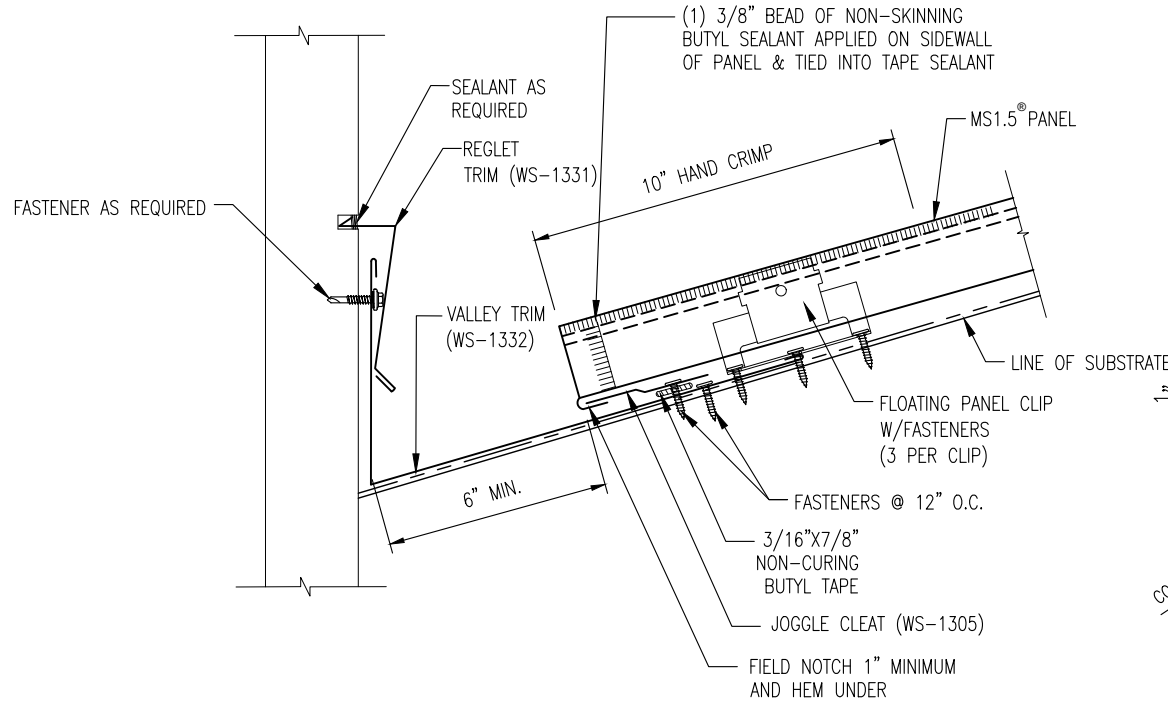

* 6" MAX CLIP PLACEMENT FROM END OF PANEL

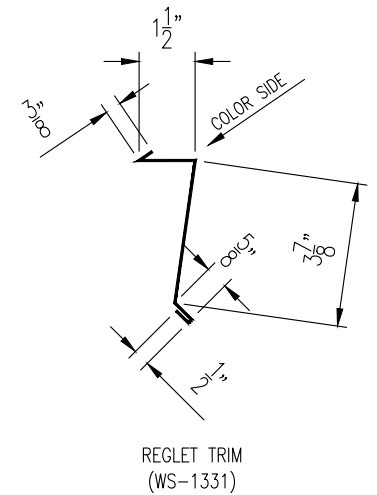
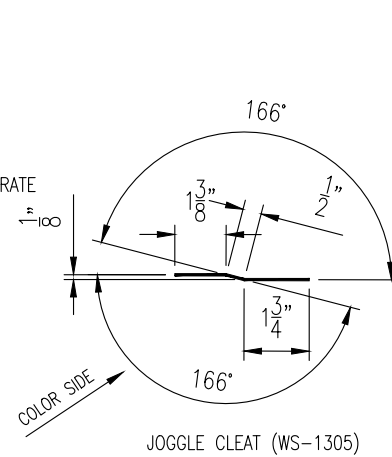
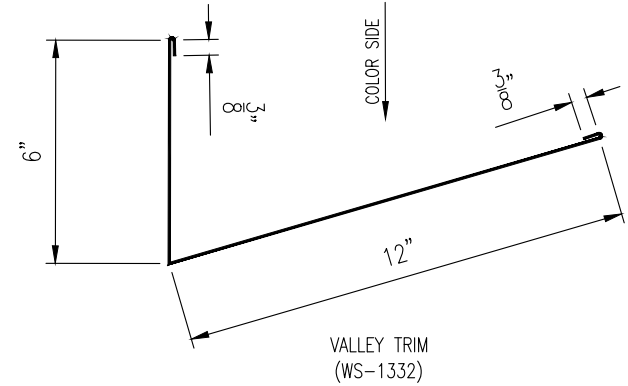

GUAGE: _____	COLOR: _____
LENGTH: _____	FINISH: _____
MATERIAL: _____	



Western States Metal Roofing

901 W. Watkins St.
Phoenix, AZ 85007
www.westernstatesmetalroofing.com

Phone: (602) 495-0048
Fax: (602) 261-7726
877-PURLINS (787-5467)



HALF VALLEY DETAIL (FLOATING)	DATE:	
	A	11-12-25
PANEL TYPE: MS1.5® STANDING SEAM	REV:	
	DETAIL #:	MS1.5-WSD-W25

FIELD NOTCH ZEE CLOSURE AT RIB
NON-SKINNING BUTYL SEALANT APPLIED TO ENDS OF ZEE CLOSURE

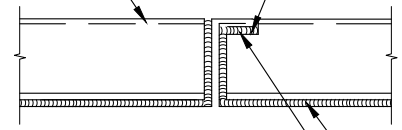

SECTION X-X
3/16"x7/8" BUTYL TAPE

INSTALLATION NOTE:
CLOSE HEM OF PANELS WITH DUCK BILLS TO ALLOW NOTCHED ZEE CLOSURE TO FIT TIGHTLY TO PANEL

**** WSMR Recommends Sharkskin® Ultra SA for Underlayment.**

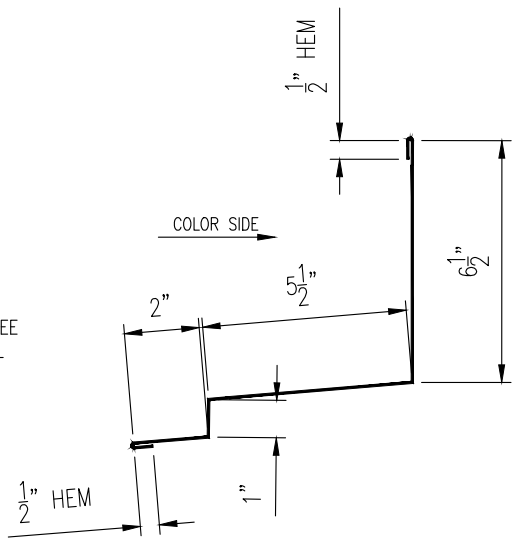

HEAD WALL FLASHING (WS-1324)

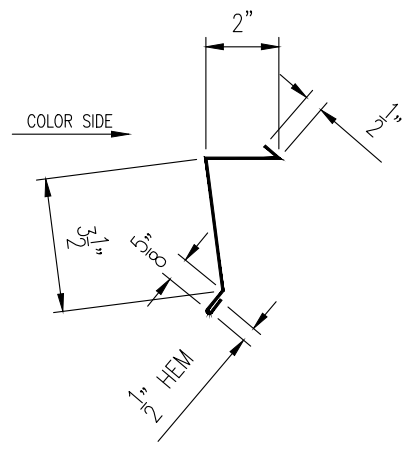

REGLET FLASHING (WS-1313)

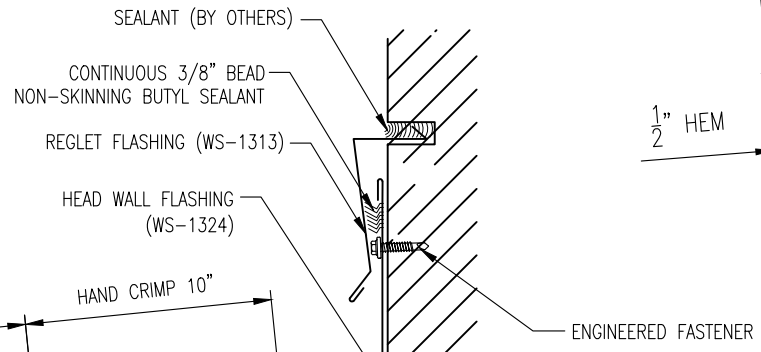

SEALANT (BY OTHERS)
CONTINUOUS 3/8" BEAD NON-SKINNING BUTYL SEALANT
REGLET FLASHING (WS-1313)
HEAD WALL FLASHING (WS-1324)
ENGINEERED FASTENER
18GA. CONT. PANEL END SUPPORT (WS-1312)
NON-SKINNING BUTYL SEALANT APPLIED TO ENDS OF ZEE CLOSURE
3/16"x7/8" CONTINUOUS BUTYL TAPE
3/16" BULB RIVET AS REQ'D (4) PER PANEL PAINTED TO MATCH. USE (4) FASTENERS OVER OPEN PURLINS
LINE OF SUBSTRATE

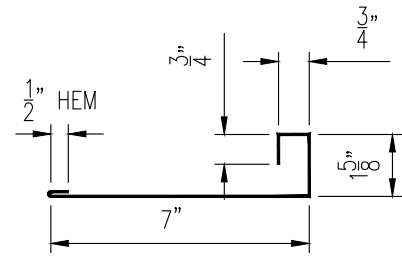

18 GA. CONT. PANEL END SUPPORT (WS-1312)

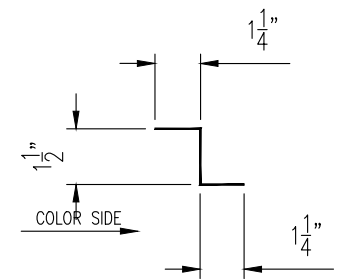

ZEE CLOSURE (WS-1314)

* - FIRST 10" OF PANEL DOWNHILL OF HEAD WALL NEED TO BE 180° HAND CRIMPED TO GET SEAMER ON/OFF

GUAGE: _____	COLOR: _____
LENGTH: _____	FINISH: _____
MATERIAL: _____	



Western States Metal Roofing

901 W. Watkins St.
Phoenix, AZ 85007
www.westernstatesmetalroofing.com

Phone: (602) 495-0048
Fax: (602) 261-7726
877-PURLINS (787-5467)



HEAD WALL DETAIL (FLOATING)	DATE:	
	A	11-12-25
PANEL TYPE: MS1.5® STANDING SEAM	REV:	
	DETAIL #:	MS1.5-WSD-W26

CUSTOM TRIM

GAUGE: _____	COLOR: _____
BREAKS: _____	FINISH: _____
LENGTH: _____	STRETCH OUT: _____
MATERIAL: _____	
CUSTOM TRIM NAME: _____	DATE:
	A 11-12-25
PANEL TYPE: MS1.5 [®] STANDING SEAM	REV: _____
	DETAIL #:



Western States Metal Roofing

901 W. Watkins St.
Phoenix, AZ 85007
www.westernstatesmetalroofing.com

Phone: (602) 495-0048
Fax: (602) 261-7726
877-PURLINS (787-5467)





Finishes You've Never Seen Before®

WESTERN STATES METAL ROOFING

(877) 787-5467 • WESTERNSTATESMETALROOFING.COM

REQUEST A FREE METAL COLOR SAMPLE • Affordable Delivery throughout USA, Canada, and Mexico

Phoenix: 901 W Watkins St., Phoenix, AZ 85007

☎ (602) 495-0048

✉ sales@westernstatesmetalroofing.com

Tucson: 4975 E. Drexel Rd., Tucson, AZ 85706

☎ (520) 574-4247

✉ tucsonsales@westernstatesmetalroofing.com

Texas: 15023 County Rd 545, Nevada, TX 75173

☎ (972) 843-4343

✉ texas-sales@westernstatesmetalroofing.com

Washington: 3610 N. Barker Rd. STE C Spokane Valley, WA 99027

☎ (509) 418-2833

✉ washington-wsmr@westernstatesmetalroofing.com



www.facebook.com/westernstatesmetalroofing/



www.instagram.com/westernstatesmetalroofing/



www.twitter.com/weststatesmetal



www.youtube.com/westernstatesmetalroofing



www.linkedin.com/company/western-states-metal-roofing



www.pinterest.com/westernstatesmetalroofing/



www.houzz.com/pro/raynaann/western-states-metal-roofing